

GRANT MULTI PASS OIL FIRED BOILER

DOC. 022 REV: 9 JAN. '05

INSTALLATION AND SERVICING MANUAL

Multi Pass

Indoor and Boiler House Models

Floor Standing Oil Boilers
providing
Central Heating and Domestic Hot Water

Before installing this product refer to
Health and Safety Instruction on page 44

Models for use with
Kerosene or Gas oil

Complies with the EC Low voltage, Electromagnetic compatibility and Boiler efficiency Directives



89/336/EEC
73/23/EEC
92/42/EEC

It is important that the boiler is installed and serviced
as described in these instructions

After installing the boiler leave these instructions with the User





LIST OF CONTENTS

Section	Subject	Page
1	User instructions	3
2	Technical information	6
3	General boiler information	10
4	Boiler installation	24
5	Commissioning	29
6	Information for the user	31
7	Boiler servicing	32
8	Wiring diagrams	37
9	Fault finding	39
10	Burner spares	42
11	Health and safety information	44
12	EC declaration of conformity	46

COMMISSIONING REPORT

Date:

Commissioning engineer: Tel. No:

Boiler model/output:Btu/h Fuel type: Kerosene or Gas oil

Nozzle size: Pump pressure: Air setting:

Flue gas % CO₂: Net flue gas temp: Smoke No:

SERVICE LOG

It is recommended the the appliance is installed, commissioned and serviced by a 'Competent person' such as a suitably qualified Oftec registered technician.

Date	% CO ₂	Net flue gas temp.	Smoke No.	Service Engineer/Tel. No.



1.1 About your boiler

The boiler will provide domestic hot water and central heating and is fully automatic once switched on. Kitchen models have a 'boiler on' neon, see Fig. A, which lights when the boiler is switched on, but does not necessarily indicate the burner is firing.

If your Kitchen model has a timer fitted, it will provide hot water and central heating during the periods set on the timer.

1.2 Boiler controls (see Fig. A or B)

To access the Kitchen model controls, open the front door from the right (may be altered to open from the left if required).

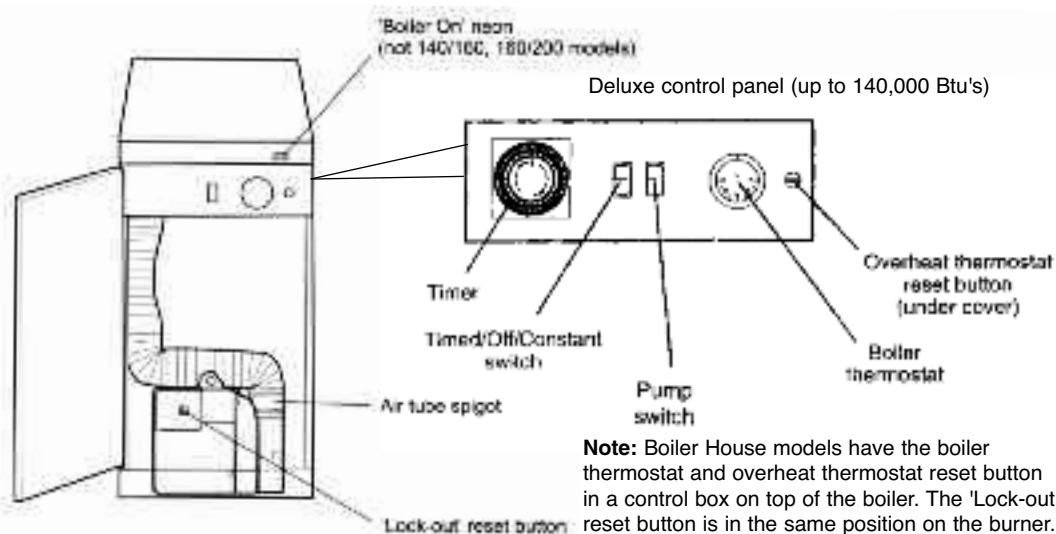

Controls for Multi Pass Kitchen models - Fig. A

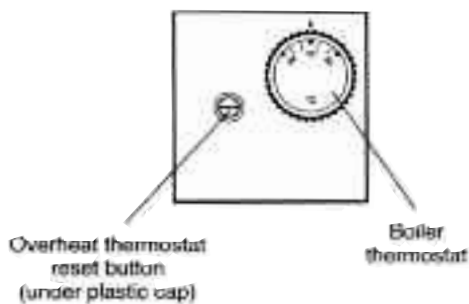

Controls for Boiler House models – Fig. B

1.3 Lighting your boiler (see Fig. A or B)

1. **Ensure that** - There is sufficient fuel, of the correct type, in the supply tank and all fuel supply valves are open. The water supply is on. The electricity supply to the boiler is off. The boiler On/Off switch is set to OFF (Kitchen models). The room thermostat (if fitted) is at the desired setting. The boiler thermostat is set to the required setting (see section 1.7).

2. Switch on the electricity supply to the boiler.

Note: Boiler House models will light at this stage.

3. For Kitchen models, set the On/Off switch to ON and, if fitted, the programmer (CH or HW) to ON. The boiler will now light automatically.

4. TIMER – Deluxe control panel (Optional)

Description and setting

The 24 hr. timer dial has a number of tappets around its edge, each corresponding to 15 minutes. When tappets (or groups) are moved in towards the centre of the dial, the timer will be in an 'on' position

during that period and the boiler will operate.

A typical timer setting for a working family could be as follows:

The groups of tappets between 6.00 and 8.00, and 16.00 and 22.00 set towards the centre as shown in Diagram below. This would provide two 'on' periods for central heating from 6 a.m. to 8 a.m., then again from 4 p.m. to 10 p.m.

To set the timer to the correct time of day, turn

the dial (outer tappet ring) **clockwise** until the time of day is against the time indicator arrow head. The diagram shows the timer at midnight (24.00).

IMPORTANT: Do not turn the dial anti-clockwise.

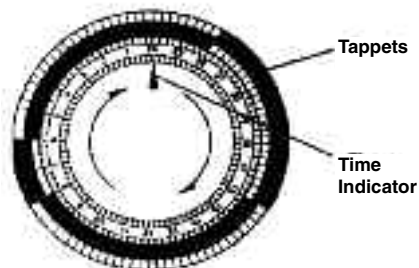

Timer Setting

Fig. C



1.4 *Turning off your boiler (see Fig. A or B)*

Kitchen models for short periods - Set the On/Off to OFF.

To restart, simply set the switch to ON.

Kitchen models for long periods: Set the On/Off switch to OFF and switch off the electricity supply to the boiler. If required, the fuel supply valve may be closed and the water and electricity supplies turned off at the mains.

To restart, refer to the full lighting instructions above.

Boiler House models for short periods - Switch off the electricity supply to the boiler.

To restart, switch on the electricity supply to the boiler.

Boiler House models for long periods - Switch off the electricity supply to the boiler. If required the fuel supply valve may be closed and the water and electricity supplies turned off at the mains.

To restart, refer to the full lighting instructions given in section 1.3.

1.5 *Points to check if burner fails to light*

- 1 Check that the boiler On/Off switch is ON.
- 2 Check that the programmer (if fitted) is working and is in an 'on' period.
- 3 Check that all thermostats are set to the desired setting and are calling for heat.
- 4 Check if the burner 'Lock-out' reset button is lit. If it is, press it to start the burner. If the burner fails to light and goes to 'Lock-out' again, check that you have sufficient fuel in the storage tank and that the fuel supply valve is open.
- 5 Ensure that a fuse has not blown or that the electricity supply has not failed.
- 6 Check to see if the safety thermostat has operated (see section 1.7).

If the burner still fails to light after carrying out these checks then a fault exists. Switch off the electricity supply to the boiler and contact your Service Engineer.

1.6 *About your fuel*

Multi Pass boilers will operate on either Class C2 Kerosene or Class D Gas Oil to BS 2869:1998. Your Installer will have informed you of the type of fuel your boiler has been set to use and he will have marked this on the boiler data label. You should always quote the type of fuel you require when ordering from your supplier.

Note: Balanced flue models (flue terminal through the wall) must only be used with Kerosene).

Do not wait until the fuel runs out before you order some more. Sludge in the bottom of the tank may be drawn into the fuel lines. If it is possible, switch off the boiler when the new supply is delivered and leave the fuel to settle for an hour before restarting the boiler.

1.7 *General notes and care of your system*

- 1 **Boiler thermostat** - This control allows the temperature of the water leaving the boiler to heat the radiators and domestic hot water to be adjusted.

Note: If you have a cylinder thermostat on your hot water cylinder, this will control the temperature of your domestic hot water. The boiler thermostat setting must be equal to or above the cylinder thermostat setting to enable the cylinder thermostat to control the domestic hot water system.

The boiler thermostat has an operating range of 65 to 85°C. The following settings are recommended:-

- a Heating and hot water in Winter 85°C
- b Hot water only in Summer 65°C

- 2 **Burner Lock-out reset button** - If there is a burner malfunction, a built-in safety circuit switches the burner off and the Lock-out reset button will light. Usually such malfunctions are short lived and pressing the reset button will restore normal operation. If the burner continually goes to 'Lock-out' a fault exists **or** the fuel supply is low. If you have sufficient fuel, you will need to call your Service Engineer.
- 3 **Safety thermostat** - Your boiler is fitted with a safety overheat thermostat which will automatically switch off the boiler in the case of a control malfunction causing overheating.

If your boiler goes off and you try to light it but nothing happens and the 'lock-out' reset button on the burner is not lit, the overheat thermostat has probably operated. The boiler will not light until the thermostat is reset. To reset, unscrew the small plastic cap (see Fig. 21 or 21a), press the button then replace the cap.

If this condition continually repeats, contact your Service Engineer.

- 4 **Timer (if fitted)** – Refer to Section 1.4



- 5 **Ventilation** - Always ensure that the boiler has adequate ventilation. Any ventilation openings provided by the Installer **must not** be obstructed. Periodically check that they are clear.

Do not attempt to 'box in' the boiler or build a compartment around it before consulting your Installer.

Do not place any combustible material around or on the boiler or flue pipe.

- 6 **Flue terminal** - The flue terminal on the outside wall **must not** be obstructed or damaged.

In severe conditions check that the terminal does not become blocked by snow.

- 7 **Frost protection** - Your Installer may have fitted a frost thermostat. If not, and you are likely to be away for a short time, leave the boiler on with the boiler thermostat set at a low setting. For longer periods the boiler and system should be drained. Contact your Service Engineer for draining and filling the system.

- 8 **Cleaning and servicing** - Lightly wipe over the case with a damp cloth and a little detergent. **Do not** use abrasive pads or cleaners.

You should have your boiler serviced at least once a year to ensure safe and efficient operation. Contact your Service Engineer for further details.

- 9 **Failure of electricity supply** - If the electricity supply fails, the boiler will not operate. It should relight automatically when the supply is restored.

1.8 Electricity supply

The boiler requires a 230/240 V ~ 50 Hz supply. It must be protected by a 5 Amp fuse.

Warning: This appliance must be earthed.

1.9 Sealed central heating system

If your boiler is operating on a sealed heating system, the installer will have pressurised the system and should have told you (or set it on the pressure gauge) the system pressure when cold (this is normally between 0.8 and 1.0 bar, which will increase slightly when hot). If the pressure (when cold) is below the set pressure mentioned above, you should contact your Installer or Service Engineer to re-pressurise the system. If the system requires frequent re-pressuring, ask your Installer or Service Engineer to check the heating system for leaks.

The boiler or system will be fitted with an automatic air vent to remove air from the system. Any air trapped in the radiators should be removed by venting the radiators using the vent screw at the top of each radiator. Only vent a radiator if the top is cool and the bottom is hot. Excessive venting will reduce the system pressure, so only vent when necessary and check the system pressure as mentioned above. Re-pressurise the system if necessary.

Note: Your system may incorporate a 'Top-Up' vessel, advice on how to use it should be obtained from your installer.

The boiler or system will be fitted with a safety valve to release excess pressure from the system. If water or steam is emitted from the end of the safety valve discharge pipe, switch off the boiler and contact your Installer or Service Engineer.

The expansion vessel air charge must be checked annually. Failure to maintain an adequate air charge in the vessel may invalidate the warranty.



2 – BOILER TECHNICAL INFORMATION

2.1 Boiler technical data

Model		70/90	90/140	140/160	160/200
Water content	litre	19	26	36.0	36.0
	gal	4.2	5.7	7.9	7.9
** Weight (dry)	kg	117 (98)*	148 (125)*	210 (197)*	210 (197)*
	lb	258 (216)*	326 (275)*	462 (433)*	462 (433)*
Max. heat input (Kerosene)	kW	27.6	43.7	49.4	62.5
	Btu/h	94 200	149 140	169 600	212 000
Flow and return connections		1" BSP	1 1/4" BSP		
Flue diameter (conventional)		100 mm (4 in)	125 mm (5 in)	150 (6 in)	
Waterside resistance					
Flow / Return temp. difference of 10°C		8.7 mbar	37.5 mbar		
Flow / Return temp. difference of 20°C		2.7 mbar	6.1 mbar		
Maximum static head		28 m			
Minimum circulating head		1 m			
Boiler thermostat range		65 to 85°C			
Limit (safety) stat switch off temp.		111°C ± 3°C			
Max. hearth temperature		Less than 50°C			
Electricity supply		230-240V ~ 50 Hz Fused at 5 Amp			
Motor power		90 W max.	125 W max.		
Starting current		2.6 Amp	2.5 Amp		
Running current		0.85 Amp	0.95 Amp		
Oil connection		1/4" BSP Male (on end of flexible fuel line)			
Conventional flue		Minimum flue draught - 8.7 N/m ² (0.035 in wg)			
		Maximum flue draught - 37 N/mn ² (0.15 in wg)			
Max. operating press. Sealed system		2.5 bar			
	Open system	3 bar			

* Boiler House model only

** Weight includes burner but excludes flue



2.2 Multi Pass Oil Boilers using Class C2 kerosene

Note: All boilers are despatched for use with kerosene.

Model	Heat Output		Net eff** %	Net Heat Input		Nozzle	Oil press. (bar)	Smoke No.	Burner head	Fuel flow rate (kg/h)	Flue gas temp. (°C)	CO2 %	Flue gas mass (kg/h)	Head Setting
	(kW)	(Btu/h)		(kW)	(Btu/h)									
70/90	20.5	70 000	96.0	21.4	73 000	0.60/60°EH	8.50	0 - 1	LD3	1.87	167	12.0	30.0	
	*23.5	80 000	95.7	24.5	83 780	0.75/60°EH	7.00	0 - 1	LD3	2.13	166	12.0	34.4	
	26.4	90 000	95.8	27.6	94 200	0.75/60°EH	9.50	0 - 1	LD3	2.40	168	12.0	38.7	
90/140	32.2	110 000	94.5	34.1	116 400	1.00/60°ES	8.00	0 - 1	LD3A	3.18	180	12.0	47.4	
	*36.7	125 000	94.1	38.9	132 800	1.10/80°EH	8.50	0 - 1	LD3A	3.24	185	12.0	54.0	
	41.0	140 000	93.8	43.7	149 140	1.25/60°S	8.25	0 - 1	LD3A	3.80	184	12.0	60.5	
140/160	*41.0	140 000	N/A	43.7	149 140	1.25/60°S	7.50	0 - 1	K/KA	3.80	185	12.0	60.4	
	47.0	160 000	N/A	49.7	169 600	1.35/60°S	8.25	0 - 1	K/KA	4.34	195	12.0	68.3	
160/200	47.0	160 000	N/A	49.7	169 600	1.35/60°S	8.25	0 - 1	C/KA	4.34	195	12.0	68.3	
	*52.8	180 000	N/A	55.9	190 800	1.50/60°S	8.00	0 - 1	C/KA	4.76	195	12.0	77.3	
	58.6	200 000	N/A	62.1	212 000	1.65/60°S	9.25	0 - 1	C/KA	5.39	195	12.0	86.4	
140/160 RIELLO G7	41.0	140 000	93.8	43.7	149 140	1.25/60°S	9.00	0 - 1	G7	4.63	185	12.5	60.4	2
	46.6	160 000	94.3	49.4	169 600	1.35/60°S	8.50	0 - 1	G7	5.10	195	12.5	68.3	3
160/200 RIELLO G7	46.6	160 000	94.3	49.4	169 600	1.35/60°S	8.50	0 - 1	G7	5.10	195	12.5	68.3	3
	52.75	180 000	94.3	55.9	190 800	1.50/60°S	8.50	0 - 1	G7	5.77	195	12.5	77.3	6 (Full open)
	59.0	200 000	94.4	62.5	212 000	1.65/60°S	10.00	0 - 1	G7	6.46	195	12.5	86.4	6 (Full open)

Notes:

1. The data given above is approximate only and is based on the boiler being used with a low level balanced flue.
2. The above settings may have to be adjusted on site for the correct operation of the burner.
3. Gas Oil is **not** suitable for use with low level balanced flue.
4. The installer **must** amend the boiler data level if the type of fuel or nozzle used is changed.
5. The 70/90 and 90/140 models use Riello burners. The 140/160 and 160/200 models use EOGB Sterling 90 burners for Balanced Flue or Riello G7 for Conventional Flue.
6. * Indicates the factory set output.
7. ** Net thermal efficiency (BSRIA).
8. The net flue gas temperatures given are $\pm 10\%$.
9. When commissioning, or when the output or fuel is changed, the air damper **must** be adjusted to obtain the correct CO₂ level and the installer **must** amend the data label.
10. ***Flue gas temperatures taken at combustion door test point will be approximately 25°C higher.



2 – BOILER TECHNICAL INFORMATION

2.3 Multi Pass Oil Boilers using Class D gas oil

Model	Heat Output		Net eff** %	Net Heat Input		Nozzle	Oil press. (bar)	Smoke No.	Burner head	Fuel flow rate (kg/h)	Flue gas temp. (°C)	CO2 %	Flue gas mass (kg/h)	Head Setting
	(kW)	(Btu/h)		(kW)	(Btu/h)									
70/90	20.5	70 000	94.6	22.5	76 900	0.50/60°S	11.00	0 - 1	LD3	1.57	200	12.0	30.0	N/A
	23.5	80 000	94.7	25.8	87 900	0.55/60°S	12.00	0 - 1	LD3	1.80	200	12.0	34.4	“
	26.4	90 000	94.6	29.0	98 900	0.60/60°S	12.00	0 - 1	LD3	1.97	200	12.0	38.7	“
90/140	32.2	110 000	94.1	34.2	116 745	0.75/60°S	10.75	0 - 1	LD3A	2.30	185	12.0	47.4	“
	41.0	140 000	94.3	43.5	148 470	1.00/60°S	9.80	0 - 1	LD3A	2.97	184	12.0	60.5	“
140/160	41.0	140 000		43.6	148 768	0.85/60°S	16.50	0 - 1	K/KA	2.97	185	12.0	60.2	“
	47.0	160 000		50.0	170 606	0.85/60°S	20.00	0 - 1	K/KA	3.48	195	12.0	68.8	“
160/200	47.0	160 000		50.0	170 606	0.85/60°S	20.00	0 - 1	K/KA	3.95	195	12.0	68.8	“
	52.8	180 000		56.0	191 079	1.10/60°S	15.00	0 - 1	C/KA	4.47	195	12.0	76.9	“
	58.6	200 000		62.3	212 575	1.10/60°S	16.50	0 - 1	C/KA	4.98	200	12.0	85.9	“
140/160 RIELLO G7	41.0	140 000	94.2	43.5	148 470	1.00/60°S	10.0	0 - 1	G7	4.35	185	12.5	60.2	2
	47.0	160 000 ¹	94.4	49.8	169 600	1.00/60°S	12.0	0 - 1	G7	4.87	195	12.5	68.8	3
160/200 RIELLO G7	47.0	160 000	94.4	49.8	169 600	1.00/60°S	12.0	0 - 1	G7	4.87	195	12.5	68.8	3
	52.5	180 000 ¹	94.5	55.6	190 800	1.10/60°S	12.5	0 - 1	G7	5.47	195	12.5	79.6	6 (Full open)
	58.6	200 000	94.3	62.1	212 000	1.25/60°S	13.5	0 - 1	G7	6.12	200	12.5	85.9	6 (Full open)

Gas Oil Notes:

1. The data given above is approximate only.
2. The above settings may have to be adjusted on site for the correct operation of the burner.
3. Gas Oil is **not** suitable for use with low level balanced flue models.
4. The installer **must** amend the boiler data level if the type of fuel or nozzle used is changed.
5. The net flue gas temperatures given above are $\pm 10\%$.
6. The 70/90 and 90/140 models use Riello RDB burners. The 140/160 and 160/200 models use EOGB Sterling 90 burners for Balanced Flue and Riello G7 for Conventional Flue.
7. * Net thermal efficiency (BSRIA).
8. **Flue gas temperatures taken at combustion door test point will be approximately 25°C higher.



2.4 Boiler dimensions

See Figs. 1

Kitchen models

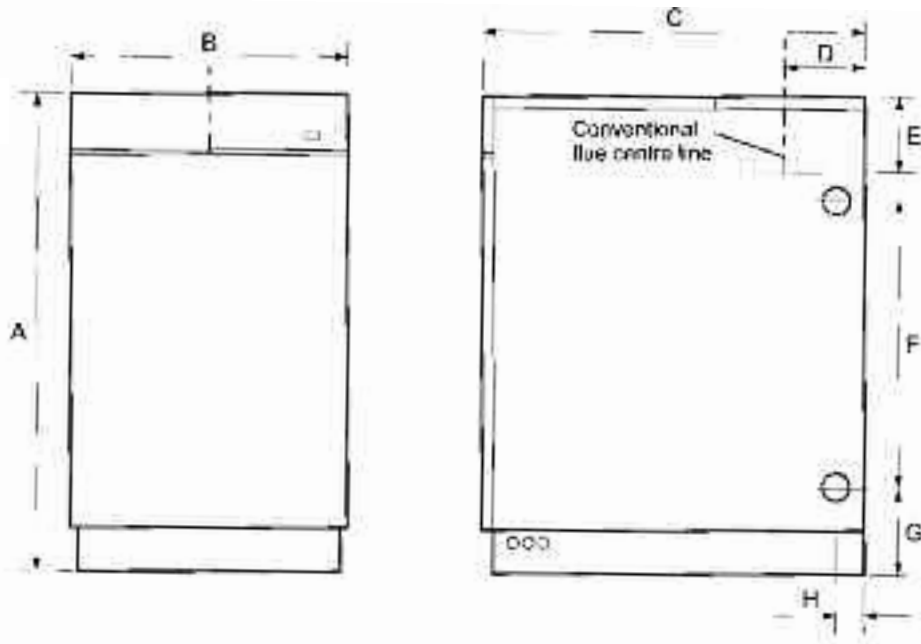

Boiler House models

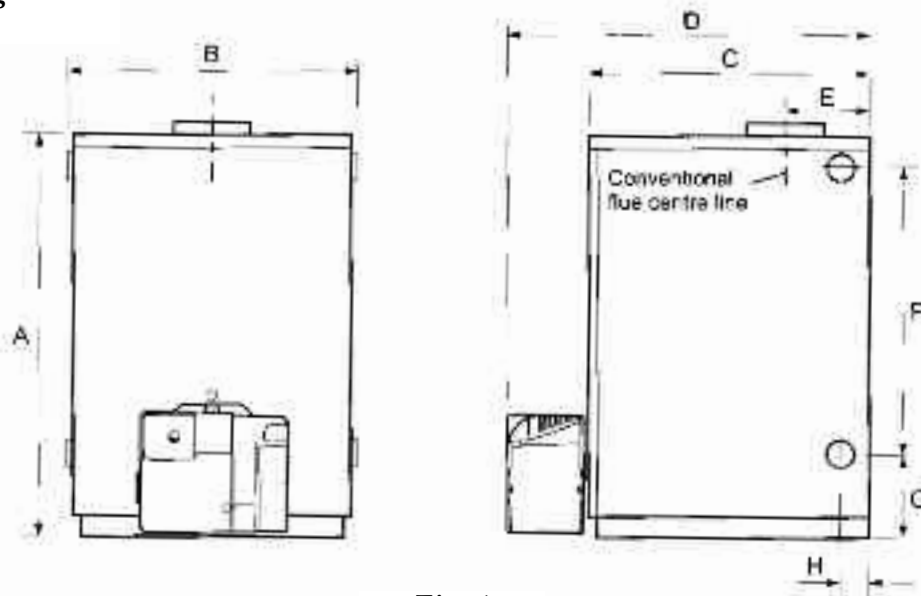

Fig. 1

Model (Kitchen)	Dimension (mm)							
	A	B	C	D	E	F	G	H
70/90	860	410	605	120	170	499	160	36
90/140	1080	410	690	125	200	550	180	54
140/160	1196	530	835	148	175	700	245	75
160/200								

Model (Boiler House)	Dimension (mm)							
	A	B	C	D	E	F	G	H
70/90	720	460	445	625	145	499	160	65
90/140	895	460	480	655	135	650	185	68
140/160	1000	550	580	765	145	700	240	70
160/200								



3.1 Boiler description

The Multi Pass range of automatic pressure jet oil boilers have been designed for use with a central heating system with indirect domestic hot water cylinder. They are not suitable for use with either a direct cylinder or a 'primatic' cylinder.

The boilers are also suitable for use on sealed central heating systems.

Four Kitchen models are available and are listed below together with their maximum outputs.

70/90	26.4 kW (90 000 Btu/h)
90/140	41.0 kW (140 000 Btu/h)
140/160	46.6 kW (160 000 Btu/h)
160/200	59.0 kW (200 000 Btu/h)

Four blue cased Boiler House models are available and are listed below together with their maximum outputs.

70/90	26.4 kW (90 000 Btu/h)
90/140	41.0 kW (140 000 Btu/h)
140/160	46.6 kW (160 000 Btu/h)
160/200	59.0 kW (200 000 Btu/h)

The boilers are supplied as Conventional flue models, if a Balanced flue version is required, a Balanced Flue Kit must be ordered. Kits available include:- Concentric Low Level Balanced Flue, and Concentric High Level Balanced Flue, all suitable for left, right or rear outlet and a Vertical Concentric Balanced Flue.

Kitchen models are supplied with the burner factory fitted. The burners for Boiler House models are supplied in a separate carton. A burner supply cable is supplied pre-wired to all burners.

All burners are pre-set for use with kerosene and are supplied ready to connect to a single pipe fuel supply system with a loose flexible fuel line (630 mm) and $\frac{3}{8}$ " to $\frac{1}{4}$ " BSP male adaptor supplied with the boiler. (The air must be set on site). If required, an additional flexible fuel line (630 mm) and $\frac{3}{8}$ " to $\frac{1}{4}$ " BSP male adaptor are available from local stockist for two-pipe oil line supply.

All models are suitable for use with Class C 2 kerosene to BS 2869:1998.

All models are suitable for use with Class D gas oil to BS 2869:1998.

Note: Only Kerosene may be used with Low Level Balanced flues.

If the fuel to be used is Gas Oil or the boiler output is to be changed, it may be necessary to change the burner nozzle and burner head. Refer to the Technical Information in sections 2.2, and 2.3.

To change the nozzle on the Kitchen models, remove the burner from the boiler then remove the nozzle as described in section 7.4. For Boiler House models, unpack the burner and remove the nozzle as described in section 7.4. To remove the baffles refer to sections 7.2 and 7.3, then refer to Figs. 27 to 30 for baffle settings. The installer **must** amend the boiler data label accordingly.

The temperature of the water leaving the boiler to heat the radiators and hot water cylinder is User adjustable from 65 to 85°C.

The boiler is fitted with an overheat thermostat (which allows it to be used on a sealed central heating system) which will automatically switch off the boiler if the heat exchanger exceeds at pre-set temperature of $111^{\circ}\text{C} \pm 3^{\circ}\text{C}$.

For Kitchen models the control panel is fitted with an ON/OFF switch, boiler thermostat control knob and the manual reset button for the overheat thermostat.

Both Boiler House models are supplied with a combined boiler and overheat thermostat with a boiler thermostat control knob and the manual reset button for the overheat thermostat.

The boiler casing door is factory fitted with the hinges on the left hand side. If required, the door may be hinged on the right hand side as follows:- Remove the hinge pin from the top of the door and the bottom hinge bracket. Refit them to the other side of the door and boiler casing. Adjust the bottom bracket until the door is correctly aligned.



3.2 Regulations to comply with

Installation of a Multi Pass boiler must be in accordance with the following recommendations:-

- a National Building Regulations
- b Local Water Undertaking Byelaws
- c Applicable Control of Pollution Regulations
- d The following OFTEC requirements:-

OFST 100 Polythene oil storage tanks for distillate fuels.

OFST 200 Fuel oil storage tanks and tank bunds for use with distillate fuels lubrication oils and waste oils.

Further information may be obtained from the OFTEC Technical Information Book 3 (Installation requirements for oil fired boilers and oil storage tanks).

The installation should also be in accordance with the latest edition of the following British Standard Codes of Practice:-

- BS 715 Metal flue pipes, fittings, terminals and accessories
- BS 799:5 Oil storage tanks
- BS 1181 Clay flue linings and flue terminals
- BS 4543:3 Factory made insulated chimneys for oil fired appliances
- BS 4876 Performance requirements for oil burning appliances
- BS 5410:1 Code of Practice for oil firing appliances
- BS 5449 Forced circulation hot water systems
- BS 7593 Code of Practice for treatment of water in heating systems
- BS 7671 Requirements for electrical installations, IEE Wiring Regulations

Failure to install and commission appliances correctly may invalidate the boiler warranty.

IMPORTANT

Before starting any work on the boiler, or fuel supply please read the health and safety information given in section 11 on page 44.

3.3 Delivery

Kitchen Conventional flue models are supplied in one pack, containing the cased boiler with the burner and control panel fitted, and literature pack with flue dress plate.

Kitchen Balanced flue models are supplied in two packs, containing the following:-

Carton 1 The cased boiler with burner fitted and control panel, and literature pack.

Carton 2 The balanced flue kit – low, high level or vertical, as ordered. A terminal guard is supplied with a low level flue kit.

Boiler House Conventional flue models are supplied in three packs, containing the following:-

Carton 1 The boiler with literature pack, but without burner.

Carton 2 The burner

Carton 3 The combined boiler and overheat thermostat.

Boiler House Balanced flue models are supplied in four packs as follows:-

Carton 1 The boiler with literature pack, but without burner.

Carton 2 The burner

Carton 3 The combined boiler and overheat thermostat.

Carton 4 The balanced flue kit - low level, high level or vertical as ordered. A terminal guard is supplied with a low level flue kit.

The following flue kits are available, refer to section 3.8 for further details.

- a Low level concentric balanced flue.
- b Low level concentric balanced flue extensions, 225 mm, 450 mm and 675 mm.
- c 90° concentric bend
- d High level balanced flue.
- e High level balanced flue extensions.
- f Vertical balanced flue.
- g Vertical balanced flue extensions.
- h 45° elbows for high level and vertical balanced flues.

Kits are available for all models up to 200 000 Btu/h.

It is recommended that the appliance is installed, commissioned and maintained by an OFTEC registered or Grant approved technician.



3.4 Fuel supply

3.4.1 Fuel storage

A painted (outside only) storage tank must be constructed to BS 799:5:1987 and OFST 200 and should include the following:-

- A fuel level gauge (not a glass type).
- A vent pipe incorporating a weatherproof termination (bend or cap) of a diameter not less than the filling pipe.
- A sludge valve.
- An outlet valve at the opposite end of the tank to the sludge valve.

The tank should be positioned in accordance with the recommendations given in BS 5410:1:1997, which gives details of filling, maintenance and protection from fire.

The tank should be suitably supported so as to obtain a slope of 20 mm per metre towards the sludge valve.

A galvanised tank must not be used.

A plastic tank may be used and must comply with OFS T100.

Note: Plastic tanks should be adequately and uniformly supported on a smooth level surface, across their entire base area.

3.4.2 Fuel pipes

- Fuel supply pipes should be of copper tubing with an internal diameter of at least 8 mm. Galvanised pipe must not be used.
- Flexible pipes must not be used outside the boiler case.
- A remote sensing fire valve must be installed in the fuel supply line (outside) where it enters the building, with the sensing head located above the burner. Recommendations are given in BS 5410:1:1997.
- A metal bowl type filter with a replaceable micronic filter must be fitted in the fuel supply line adjacent to the boiler. A shut-off valve should be fitted before the filter, to allow the filter to be serviced.
- A flexible fuel line, adaptor and 1/4" BSP isolation valve are supplied loose with the boiler for the final connection to the burner. If a two pipe system or Tiger Loop system is used an additional flexible fuel line (630 mm) and 3/8" to 1/4" BSP male adaptor are available from your local stockist.

- Flexible pipes should be inspected annually when the boiler is serviced and replaced every two years.
- The use of a 'Tankmaster' and Tiger Loop is an ideal way of delivering an oil supply to the boiler. The Tankmaster unit, fitted to the storage tank, includes a filter, sight tube, shut-off valve and fire valve. A separate fire valve is required in the fuel line (outside) where it enters the building containing the boiler. See Fig. 4.

3.4.3 Single pipe system (See Fig. 2)

- Where the storage tank outlet is above the burner the single pipe system should be used. The height of the tank above the burner limits the length of pipe run from the tank to the burner.
- As supplied the burner is suitable for a single pipe system.

3.4.4 Two pipe system (See Fig. 3)

- When the storage tank outlet is below the burner, the two pipe system should be used. The pipe runs should be as shown in Fig. 3. The return pipe should be at the same level in the tank as the supply pipe, both being 75 to 100 mm above the base of the tank. The pipe ends should be a sufficient distance apart so as to prevent any sediment disturbed by the return entering the supply pipe.
- Avoid the bottom of the tank being more than 3 m below the burner.
- A non-return valve should be fitted in the supply pipe together with the filter and fire valve. A non-return valve should be fitted in the return pipe if the top of the tank is above the burner.

4. To be used with a two-pipe system, the burner **must** be fitted with an additional flexible fuel line (a flexible fuel line (630 mm) and 3/8" to 1/4" BSP male adaptor are available from your local stockist. See section 3.4.6.

- The pump vacuum should not exceed 0.4 bar. Beyond this limit gas is released from the oil.

For guidance an installation of top outlet fuel tanks and suction oil supply sizing, see OFTEC booklet T1/139. Available at www.oftec.org.uk



Head A (m)	Maximum pipe run (m)	
	8 mm OD pipe	10 mm OD pipe
0.5	10	20
1.0	20	40
1.5	40	80
2.0	60	100

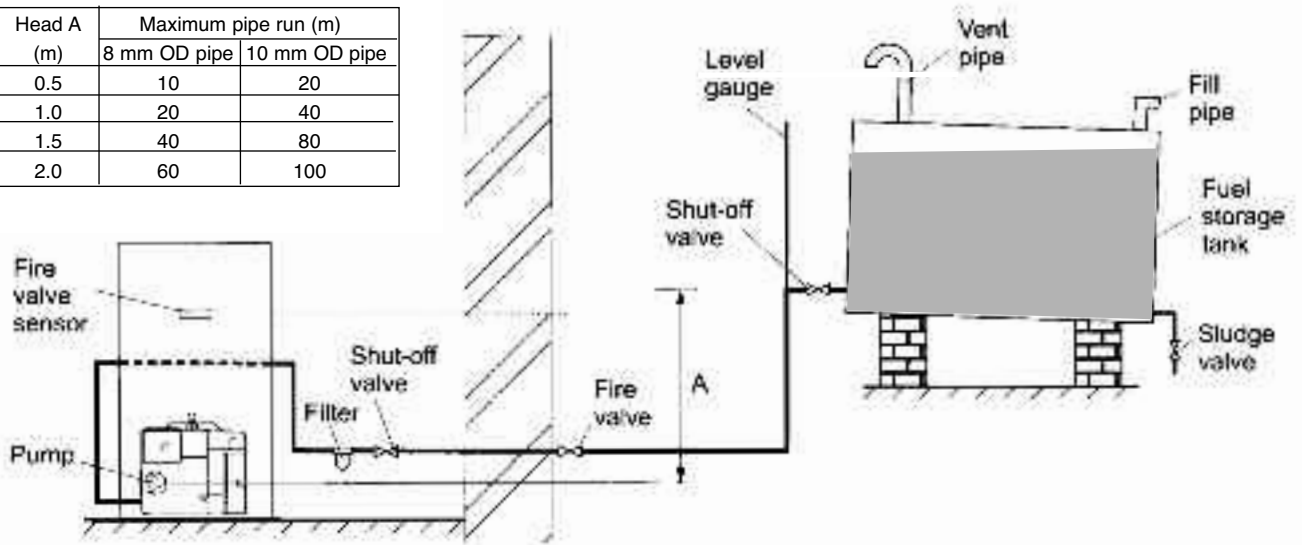
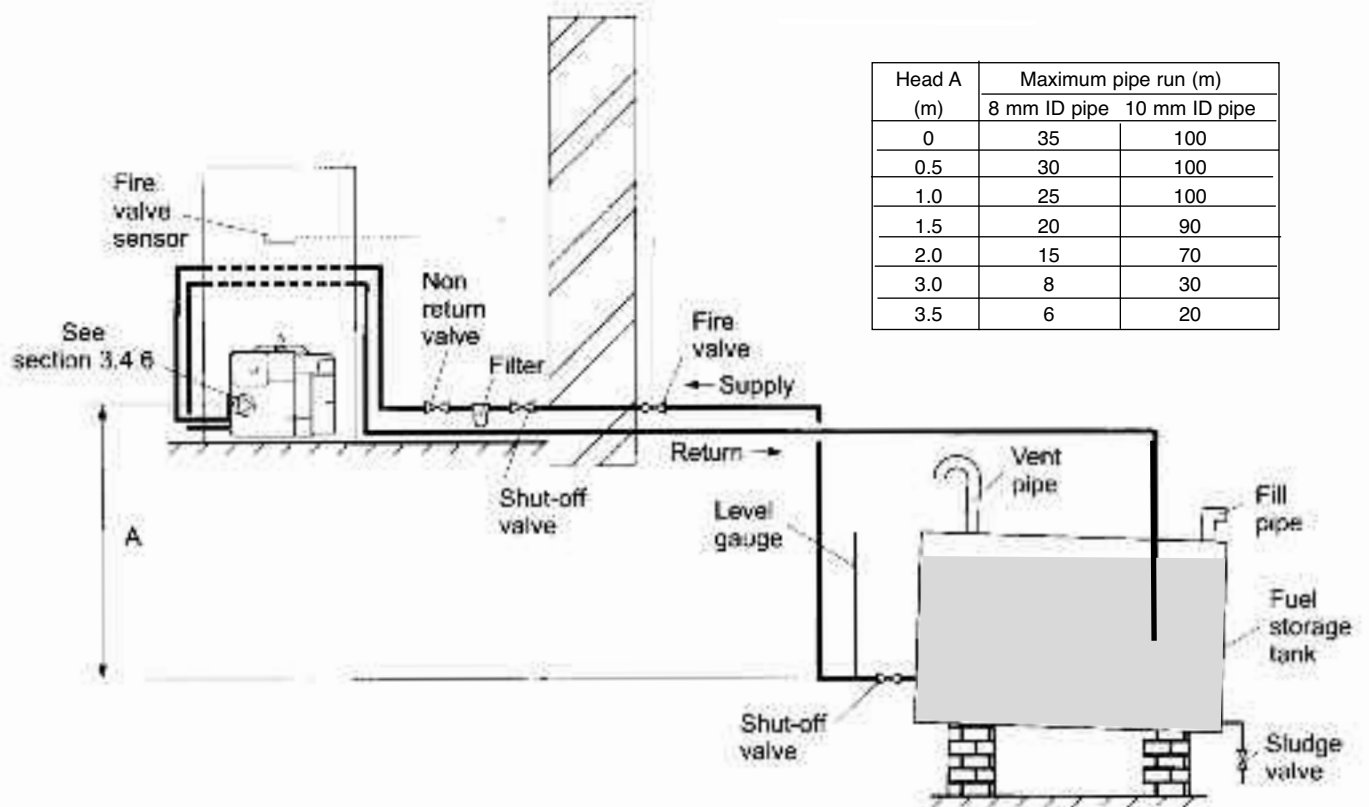

Fig. 2 - Single pipe system



Head A (m)	Maximum pipe run (m)	
	8 mm ID pipe	10 mm ID pipe
0	35	100
0.5	30	100
1.0	25	100
1.5	20	90
2.0	15	70
3.0	8	30
3.5	6	20

Fig. 3 - Two pipe system



3.4.5 Tiger Loop system (See Figs. 4 & 5)

- 1 When the storage tank is below the burner, an alternative to a two pipe system can be achieved using the Tiger Loop oil deaerator. This effectively removes the air from the oil supply on a single pipe lift.
- 2 The Tiger Loop is connected close to the boiler as a two pipe system (omitting the non-return valve) as shown in Fig. 4. Refer to the manufacturers instructions supplied with the Tiger Loop. The Tiger Loop **must** be mounted vertically.

- 3 To be used with a Tiger Loop system, the burner **must** be fitted with an additional flexible fuel line (a flexible fuel line (630 mm) and $\frac{3}{8}$ " to $\frac{1}{4}$ " BSP male adaptor are available from your local stockist). See section 3.4.6.

Note: To prevent any possibility of fuel fumes entering the building, the Tiger Loop **must** be fitted outside.

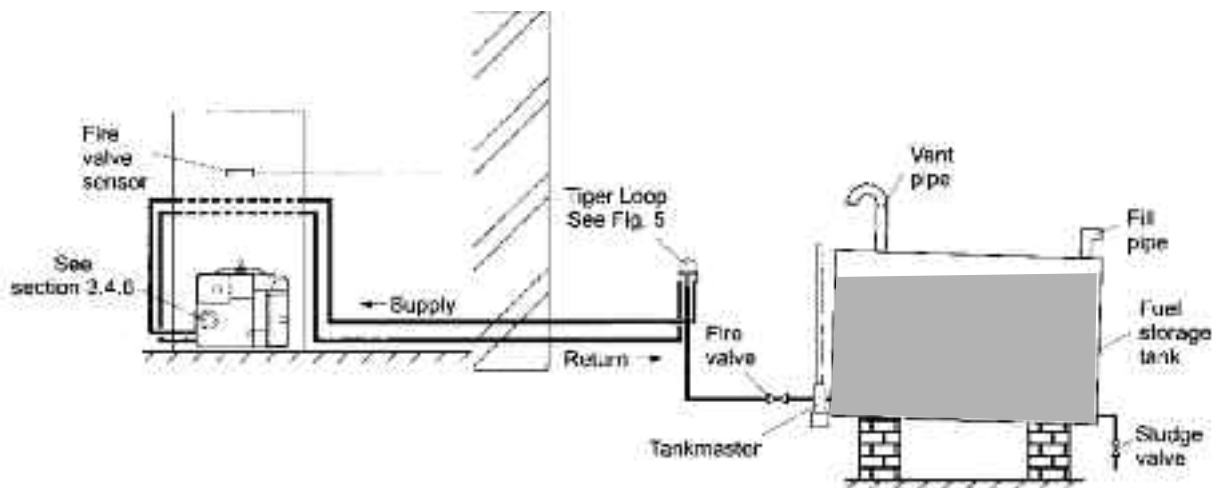

Fig. 4- Tiger loop system

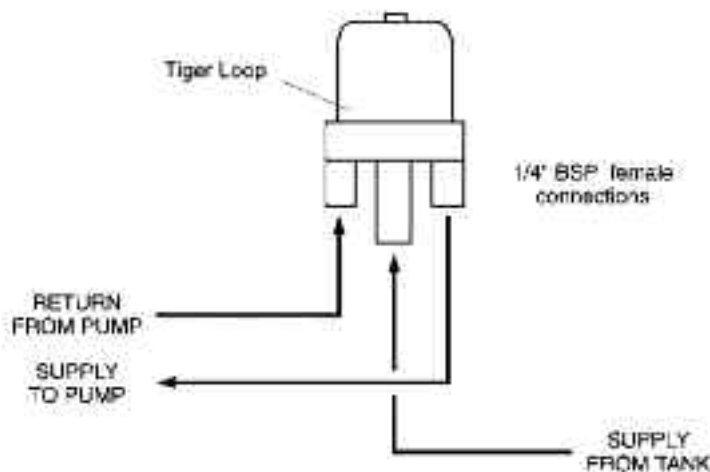

Fig. 5 - Tiger loop



3.4.6 Two pipe oil supplies

Riello RDB burner - See Fig. 6

- 1 The fuel pump is supplied for use with a single pipe supply system. For use on a two pipe system, it is necessary to fit the By-pass screw (see Fig. 6) into the tapping in the return port.
2. The By-pass screw is supplied in the boiler accessory pack.
3. Remove the plastic burner cover (two screws). To gain access on Kitchen models, it may be necessary to remove the grey plinth - loosen the screw securing the right hand side of the plinth, then withdraw the plinth forward from the right and away from the case.
4. Remove and discard the blanking plug from the return connection of the pump and fit the By-pass screw using an hexagonal key.
5. Connect the return oil flexible fuel line to the pump.
6. Connect the 3/8" to 1/4" BSP adaptor to the flexible fuel line.
7. Flexible fuel lines and adaptors are available from local stockist.
8. **Boiler House models** - Fit the burner as described in section 4.6.

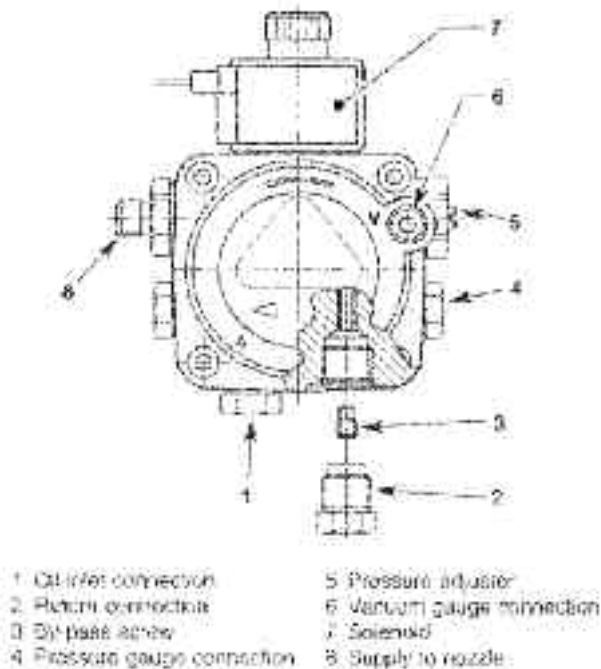

- | | |
|-----------------------------|---------------------------|
| 1 Oil inlet connection | 5 Pressure adjuster |
| 2 Return connection | 6 Vacuum gauge connection |
| 3 By-pass screw | 7 Solenoid |
| 4 Pressure gauge connection | 8 Supply to nozzle |

Fig. 6 - Riello RDB pump

EOGB Sterling 90 Burner – See Figs. 7 and 8

- 1 Remove the four screws securing the pump and cover and remove the filter.
- 2 Remove the lower cover plate fixing screw (changeover screw) and discard the 'U' shaped washer (see Fig. 7). Replace the screw.
- 3 Replace the filter and pump end cover, ensure the 'O' ring is in position.
- 4 Remove and discard the return pipe connection blanking plug from the pump (see Fig. 8) and connect the elbow of the flexible fuel pipe supplied with the burner.
- 5 Connect the flexible pipe to the rigid fuel return pipe.

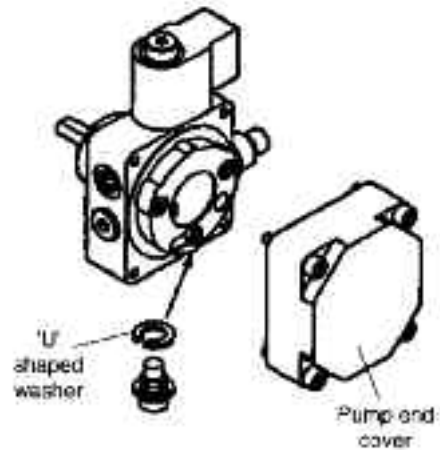
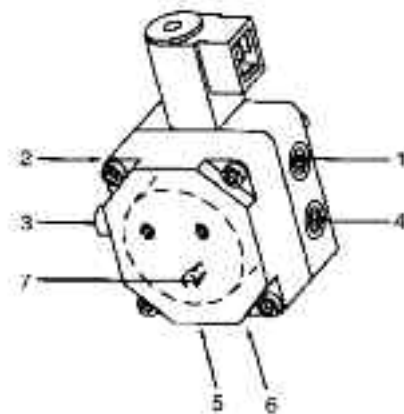

Fig. 7 - Danfoss pump



- | | |
|---------------------------------------|---------------------|
| 1 Supply to nozzle | 5 Return connection |
| 2 Pressure gauge port | 6 Inlet connection |
| 3 Pressure adjustment, 4 mm allen key | 7 Changeover screw |
| 4 Vacuum gauge port | |

Fig. 8 Danfoss BFP11 L3 pump



3.5 Electricity supply

1 A 230/ 240 V ~ 50 Hz mains supply is required.

The boiler must be earthed.

- 2 The supply must be fused at 5 Amp and there must only be one common isolator for the boiler and control system, providing complete electrical isolation.
- 3 A fused double pole switch or a fused three pin plug and shuttered outlet socket should be used for the connection.
- 4 The power supply cable should be at least 0.75mm² PVC as specified in BS 6500, Table 16.
- 5 All the wiring external to the boiler must be in accordance with the current I.E.E. Wiring Regulations.
- 6 Any room thermostat or frost thermostat used must be suitable for use on mains voltage.
- 7 In the event of an electrical fault after installation of the boiler, the following electrical system checks must be carried out:- Short circuit, Polarity, Earth continuity and Resistance to earth.

3.6 Air supply

See Figs. 9 and 10

A sufficient permanent air supply to the boiler should be provided:

- a For proper combustion of fuel and effective discharge of combustion products to the open air.
- b For the ventilation of any confined space in which the boiler is installed to prevent overheating of the boiler any equipment in and near the boiler.
- c For the satisfactory operation of any draught stabiliser which may be fitted.

It should be both the designer's and installer's concern that the air required for these functions be introduced so as to cause as little discomfort as possible to the building occupants and thus to offer them the least temptation to obstruct the ventilators.

Further details may be obtained from BS 5410:1:1997.

Notes:

For a boiler fitted in a compartment, which is ventilated as shown, no additional allowance is necessary.

Open flue - Extract fans, where needed, should be in accordance with section 4.4.7 in BS 5410 Part 1 1997.

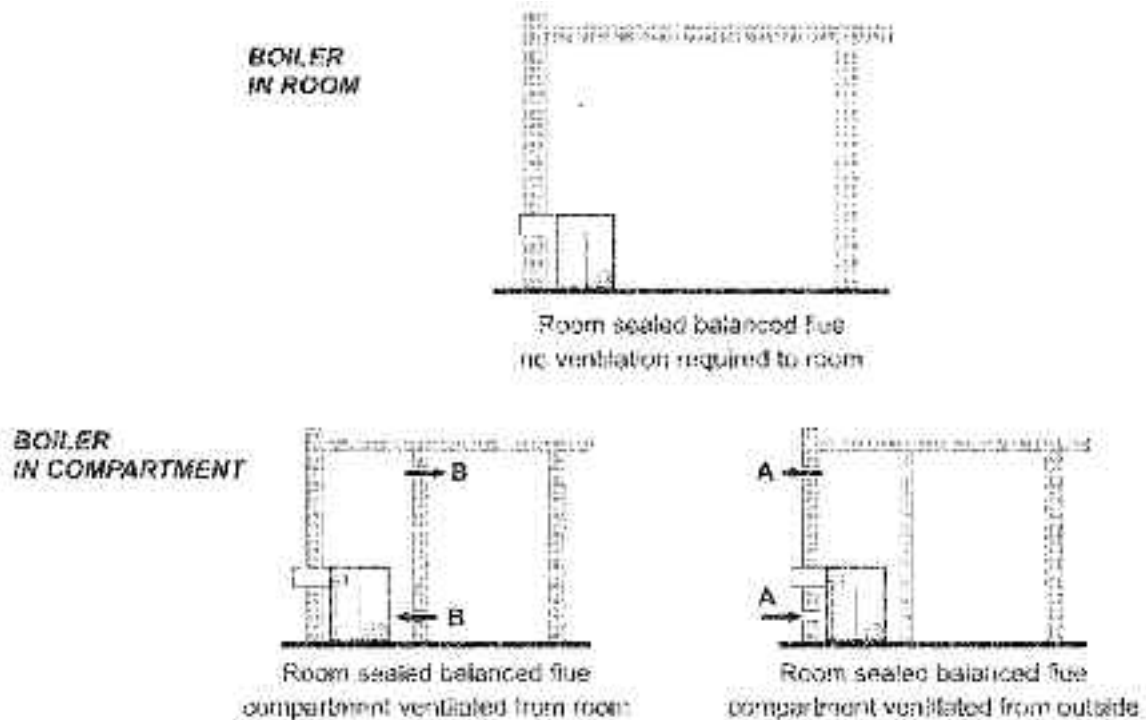

Fig. 9 – Air supply for room sealed balanced flue boilers

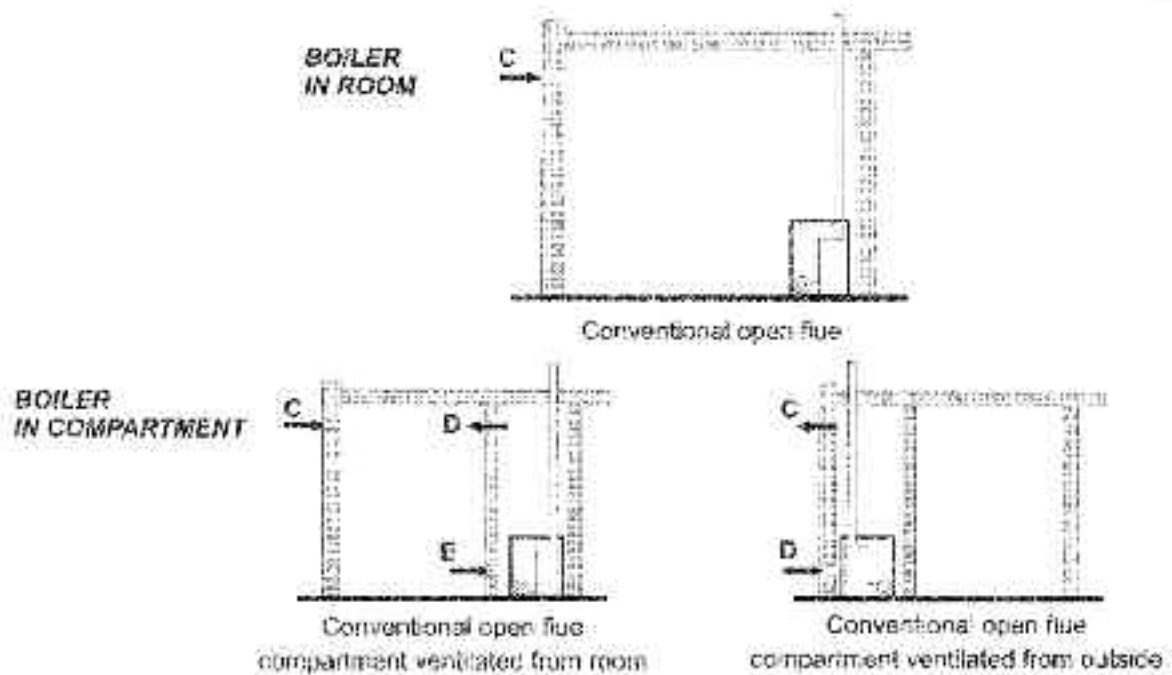

Fig. 10 – Combustion and ventilation air supply for conventional flue boilers

Minimum size of air vents required - see Figs. 9 and 10

	70/90	90/140	140/160	160/200
Vent A	145 cm ² (23 in ²)	226 cm ² (35 in ²)	256 cm ² (40 in ²)	325 cm ² (50 in ²)
Vent B	290 cm ² (46 in ²)	452 cm ² (70 in ²)	512 cm ² (80 in ²)	650 cm ² (100 in ²)
Vent C	118 cm ² (18 in ²)	198 cm ² (30 in ²)	231 cm ² (36 in ²)	295 cm ² (46 in ²)
Vent D	290 cm ² (45 in ²)	451 cm ² (70 in ²)	517 cm ² (80 in ²)	645 cm ² (100 in ²)
Vent E	436 cm ² (68 in ²)	677 cm ² (105 in ²)	776 cm ² (120 in ²)	967 cm ² (150 in ²)

Note: If the boiler is in a compartment, this **must** be added to the areas required for ventilation.

3.7 Conventional flue system

See Figs. 11 and 12

Grant boilers have high operating efficiencies. Care must be taken to ensure the flue system is suitable for the low flue gas temperatures.

- 1 An insulated flue terminating in a down draught free area, i.e. at least 600 mm above the point of exit through the roof or preferably above the ridge level, will normally provide the necessary draught of at least 8.7 N/m² (0.035 in wg) as measured close to the boiler connection. If a draught of 37 N/m² (0.15 in wg) or more is measured, then a draught stabiliser should be fitted in the flue.
- 2 The flue terminal must be at least 600 mm from any opening into the building, and 600 mm above any vertical structure or wall less than a horizontal distance of 750 mm from the terminal. See Fig. 12.
- 3 If an existing chimney is used, it must be lined with a stainless steel liner for use with fuel oil. The top and bottom of the annular space must be sealed and the void fitted with a suitable insulating material to reduce cooling of the flue gases.
- 4 If a rigid flue is used either internally or externally, it must be of the twin wall type with a stainless steel inner skin suitably insulated and weather proofed.
- 5 **The flue diameter must be as specified in section 1.1 for the size of boiler in question.**
- 6 The flue must be run upwards following as near a vertical route as possible. Horizontal runs must be avoided and no bends should have an angle of more than 45° from the vertical. There should be at least 600 mm of vertical flue above the boiler before the first bend.
- 7 A sealed cleaning door must be provided near the base of the flue.



- 8 The exposed flue pipe between the boiler and the chimney must not be of an asbestos material and aluminium must not be used in any part of the flue.
 - 9 If the draught conditions are satisfactory, the flue should terminate with a standard cowl suitable for pressure jet oil boilers. Where the flue cannot terminate above the ridge of the roof, use an 'OH' or similar type cowl where downdraughting occurs.
 - 10 Refer to the locally applicable Building Regulations, BS 5410:1 and OFTEC Installation Requirements (Books 2 and 3) for further guidance on conventional flue systems.
- 11 To allow for flue gas analysis and combustion testing, a test point is provided in the cleaning door.

3.8 Connect a conventional flue

Kitchen models

- 1 Lift off the rear part of the case top.
- 2 Remove the insulation from the rear top panel (do not discard it) and remove the blanking panel. Discard the panel, retaining the nuts and washers.

- 3 Unscrew the protective covers from the studs on the flue dress panel, supplied in the literature pack. Place the panel in position in the rear case top panel and secure in place using the washers and nuts previously removed.

Note: The first section of flue must be in single wall rigid steel vitreous enamel flue pipe.

- 4 Cut the insulation into three equal pieces and replace two - either side of the flue opening in the case top panel.
- 5 Position the flue pipe into the boiler flue socket and make good the connection using a suitable flexible high temperature sealant (e.g. Silastic or similar) and rope seal.
- 6 Position the rear section of the previously prepared case top over the first section of the flue.
- 7 Replace the rear section of the case top.

All Boiler House models

- 1 Position the flue pipe into the boiler flue socket.
- 2 Make good the connection using a suitable flexible high temperature sealant (e.g. Silastic or similar) and a rope seal.

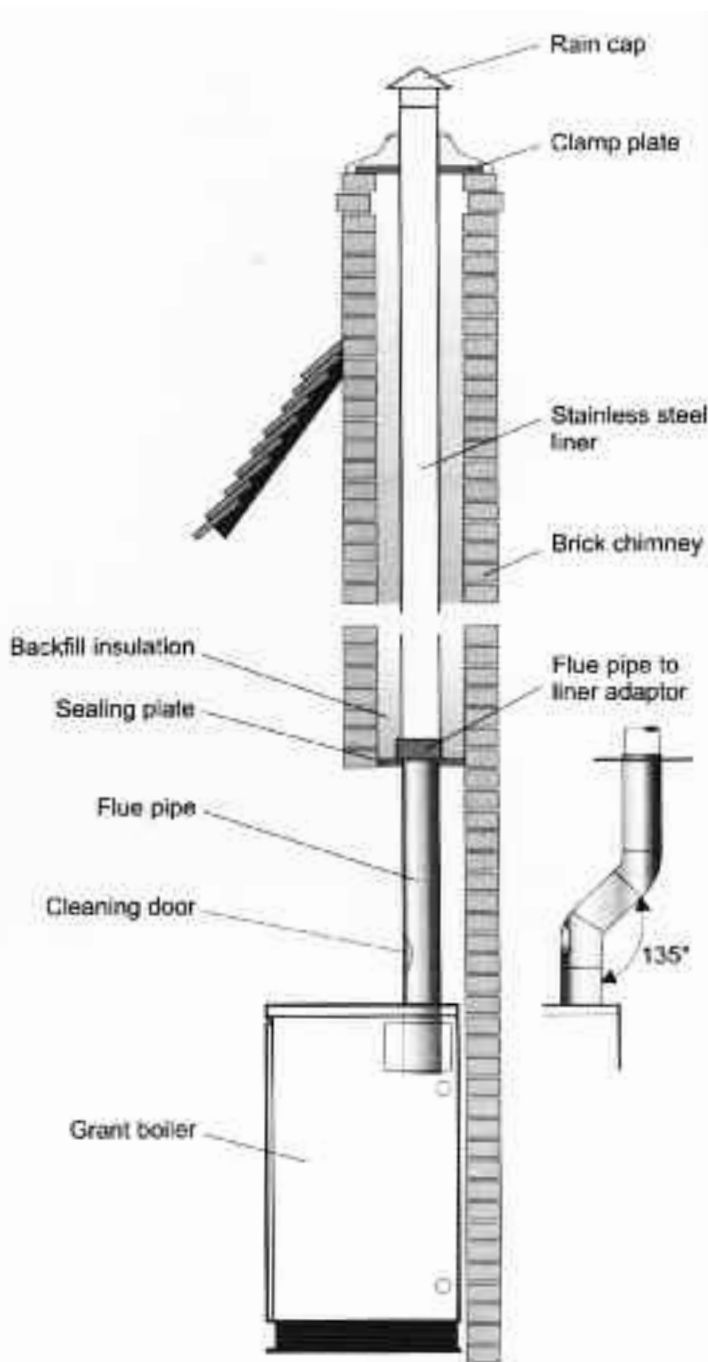

Fig. 11 – Typical conventional flue with brick chimney



3.9 *Balanced flue options*

- 1 Apart from a conventional flue/chimney, several balanced flue options are available for use with the Multi Pass boiler.
 - a **High level horizontal balanced flue** - allows the flue to rise between approximately 1.7 to 2.2 m above floor level before exiting through the rear or side wall. It is adjustable to suit the following wall thicknesses:-

Rear	215 to 450mm (approximately)
Side	120 to 350mm (approximately)

Extension kits are available which extend the flue by 950 mm, 450 mm or 275 to 450 mm telescopic.
 - b **A vertical balanced flue kit** - adjustable to 3 m (maximum 6 m with extensions).

Extension kits are available which extend the flue by 950 mm, 450 mm or 275 to 450 mm telescopic.

A choice of two waterproof flashings (flat or pitched) and a wall bracket are also available.
 - c **Concentric (round) low level horizontal balanced flue** - available in Short and Standard kits. Extensions are available which extend the flue by 225 mm, 450 mm or 675 mm. A 90° elbow is also available.

Standard Kit	To suit wall thickness mm			
	Rear Exit		Side Exit	
	Min.	Max.	Min.	Max.
70/90 Boiler House	220	400	120	300
90/140 Boiler House	230	410	130	290
140/160, 160/200 Boiler House	220	400	100	260
70/90 Kitchen & System	250	430	150	330
90/140 Kitchen & System	240	420	140	300
140/160, 160/200 Kitchen	220	400	100	260

The wall thicknesses quoted above for side flue assumes that the boiler will be spaced off the wall by a nominal 20 mm (to provide clearance for the plugs for the water connections). Water connections may be taken from one side only, if required (see paragraph 2 in section 3.12).

- 2 The minimum clearances for positioning the flue terminal are shown in Fig. 12.
- 3 If the flue terminal is fitted less than 2 m above a surface to which people have access, the terminal must be protected by a guard. A suitable guard is supplied with the low level flue kits. The guard must be fitted centrally over the flue terminal and securely fixed to the wall.

4 **The terminal should be positioned so as to avoid products of combustion accumulating in stagnant pockets around the building or entering into buildings.**

When a low level concentric (round) balanced flue is used, the terminal guard must be fitted in all circumstances to prevent objects entering the flue pipe.

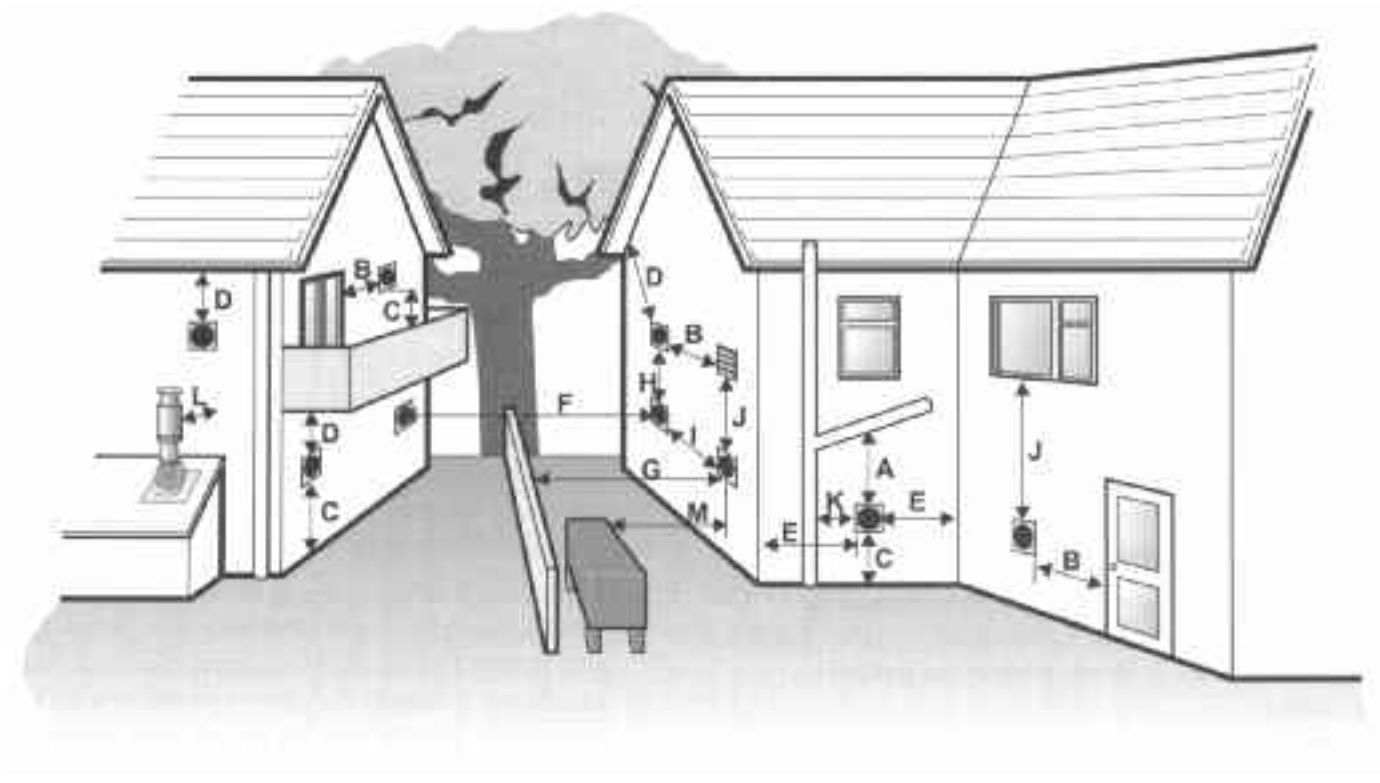

Fig. 12- Clearances for Balanced Flues

Terminal position	Min. distance (mm)
A Below a gutter or sanitary pipework	** 600
B Horizontally from an opening, air brick, window etc	600
C Above ground or balcony level	** 300
D Below eaves or balcony	*600
E From an internal or external corner	** 300
F From a terminal facing the terminal	1200
G From a surface facing the terminal	600
H Vertical from terminals on the same wall	1500
I Horizontal from terminals on the same wall	750
J Below an opening, air brick, window etc.	600
K From vertical sanitary pipework	300
L Vertical flue from a wall	600
M From an oil storage tank	1800

Notes * 75 mm with protection.
 ** 300 mm British Standards
 (600 mm recommended for high level balanced flue)

Distances measured to rim of terminal.

Clearances recommended by Grant Engineering (Irl) Limited in accordance with British Standards and Building Regulations.

- Notes:**
- 1 An opening means an openable element, such as an openable window, or a permanent opening such as a permanently open air vent.
 - 2 Notwithstanding the dimensions given, a terminal should be at least 300 mm from combustible material, e.g. a window frame.
 - 3 A way of providing protection of combustible material would be to fit a heat shield at least 750 mm wide.



3.10 Frost protection

For additional protection of either the entire heating system, or the boiler and localised pipework, it is recommended that a frost thermostat be installed. Refer to section 8 for connection details.

To protect the heating system the frost thermostat should be sited within the house in such a place that it can detect any rise and fall in the ambient air temperature, i.e. in a room with a radiator.

Where the frost thermostat is installed outside the house (to protect a boiler installed in an external boiler room or garage) or in an attic, it is recommended that it be used in conjunction with a pipe thermostat to avoid unnecessary and wasteful overheating of the property. The pipe thermostat should be located on the boiler return pipe, and set to operate at 25°C. Refer to section 8 for connection details.

3.11 Boiler location

- 1 The boiler must stand on a surface that is firm and level. It does not require a special hearth as the temperature of the boiler base is less than 50°C.
- 2 Sufficient clearance **must be** allowed at the front of the boiler to remove the burner and baffles for servicing.
- 3 **Kitchen models** - Once the boiler has been installed, a permanent worktop may be fitted over it as access to the top of the boiler is no longer required after installation.
- 4 If the boiler is to be installed with a side against a wall, allow a nominal clearance of 20 mm for the plugs for the water connections. Water connections may be taken from one side only if required (see section 3.12, paragraph 2).
- 5 **Boiler House models** - Sufficient clearance **must be** allowed around the boiler for the following:-
Access above the boiler to replace the boiler thermostat/overheat thermostat and access to remove the burner.

3.12 Water connections (kitchen & boiler house)

- 1 A high level flow and low level return connection are provided on each side of the boiler. See Fig. 1.
1" BSP connections are used on the 70/90 models.
1¹/₄" BSP connections are used on the 90/140, 140/160 and 160/200 models.

- 2 Flow and return connections should be diagonally opposed, i.e. to opposite sides of the boiler. If the boiler is to be positioned against a wall, the water connections may be taken from one side only, in which case the thermostat phials should be located on the same side as the connections..

Note: All models have two tappings (1/2" BSP) on the top for the thermostat pocket supplied with the boiler (Kitchen models) or burner (Boiler House models). The other tapping should be plugged.

- 3 A 1/2" BSP tapping is provided at the bottom right hand corner on the front of the boiler to allow the fitting of the drain tap supplied.

Plug all unused connections.

- 4 Fit drain taps in the central heating and domestic hot water systems to allow the complete system to be fully drained.

To avoid the danger of dirt and foreign matter entering the boiler the complete heating system should be thoroughly flushed out - before the boiler is connected and then again after the system has been heated and is still hot. This is especially important where the boiler is used on an old system.

For optimum performance after installation, this boiler and its associated central heating system must be flushed in accordance with the guidelines given in BS 7593:1992 'Treatment of water in domestic hot water central heating systems'.

This must involve the use of a proprietary cleaner, such as BetzDearborn's Sentinel X300 or X400, or Fernox Superfloc. Full instructions are supplied with the products, but for immediate information, please contact BetzDearborn on 0044 151 4209563 or Fernox on 0044 179 9550811.

For long term protection against corrosion and scale, after flushing, it is recommended that an inhibitor such as BetzDearborn's Sentinel X100 or Fernox MB01 or Copal is dosed in accordance with the guidelines given in BS 7593:1992.

Failure to implement the guidelines may invalidate the warranty.



3.13 Heating system diagrams

See Figs. 13, 14 and 15

3.13.1 Gravity domestic hot water - (See Fig. 13)

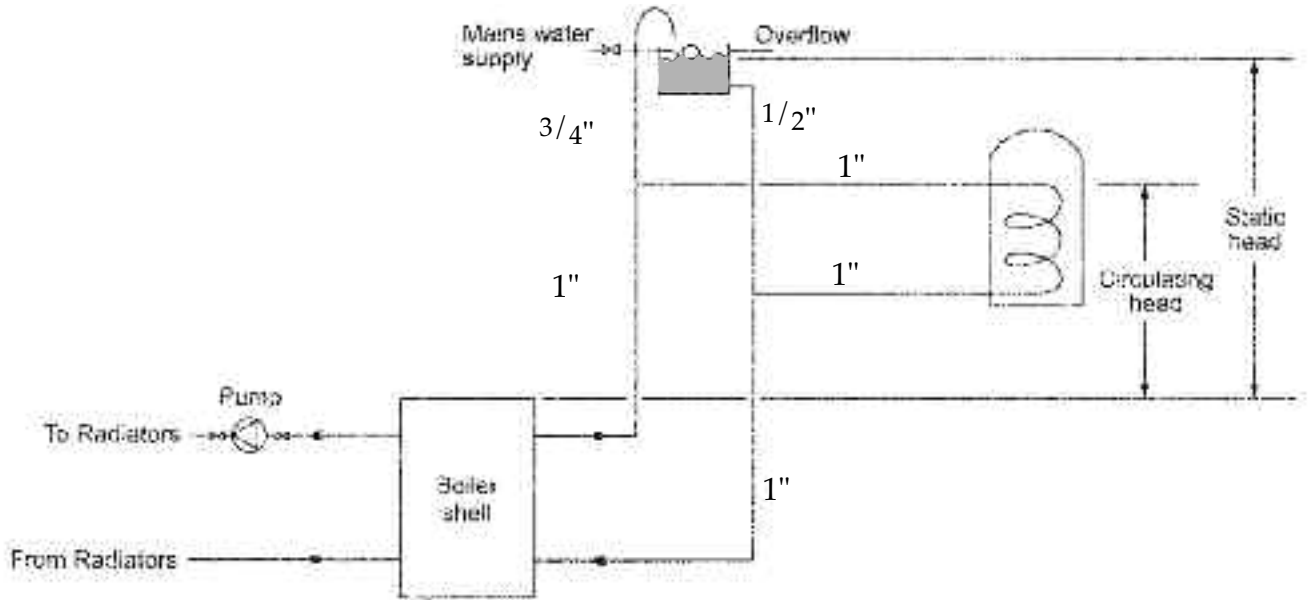

Fig. 13 - Gravity domestic hot water system

3.13.2 Fully pumped - (See Fig. 14)

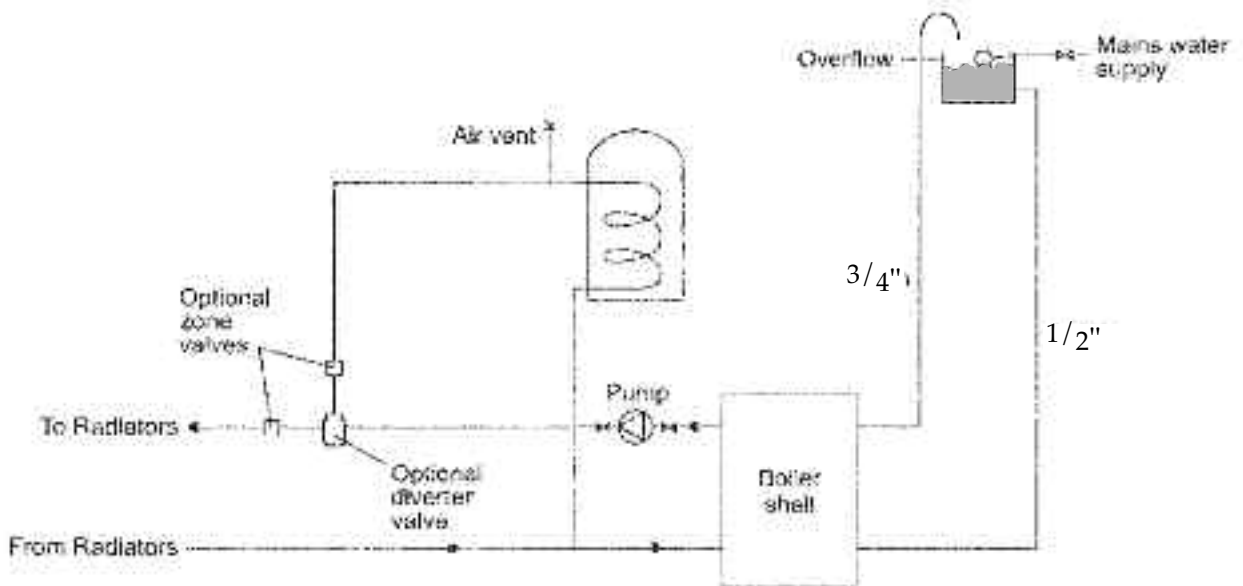

Fig. 14 - Fully pumped system



3.12.3 Sealed system - (See Fig. 15)

Grant sealed system kits and sealed system boilers, incorporating factory fitted systems and circulating pumps are available.

- 1 The boiler is suitable only for use with a sealed system complying with the requirements of BS 5449.
The maximum temperature of the central heating water is 85°C.

- 2 The boiler is supplied with the following items factory fitted:-
 - a Diaphragm expansion vessel complying with BS 4814.
 - b Pressure gauge
 - c Safety valve
 - d Approved method for filling the system.

Refer to BS 7074:1 for further guidance.

- 3 The expansion vessel can be fitted in either the return or flow pipework in any of the recommended positions as shown in Fig. 15. To reduce the operating temperature of the expansion vessel diaphragm, position it below the pipe to which it is connected. The expansion vessel may be positioned away from the system, providing the connecting pipe is not less than 13 mm diameter.
- 4 The pressure gauge should have an operating range of 0 to 4 bar.

- 5 The safety valve, set to operate at 2.5 bar, should be fitted in the flow pipework near to the boiler. The pipework between the safety valve and boiler must be unrestricted, i.e. no valves. The safety valve should be connected to a discharge pipe which will allow the discharge to be seen, but cannot cause injury to persons or property.
- 6 Provision should be made to replace water lost from the system. This can be by manual or automatic means.
- 7 An automatic air vent should be fitted to the highest point of the system.
- 8 All fittings used in the system must be able to withstand pressures up to 3 bar.
- 9 Radiator valves must comply with the requirements of BS 2767(10): 1972.
- 10 One or more drain taps (to BS 2879) must be used to allow the system to be completely drained.
- 11 For proprietary expansion vessel/valve/gauge packs, refer to the manufacturers instructions for the correct location on the heating system.

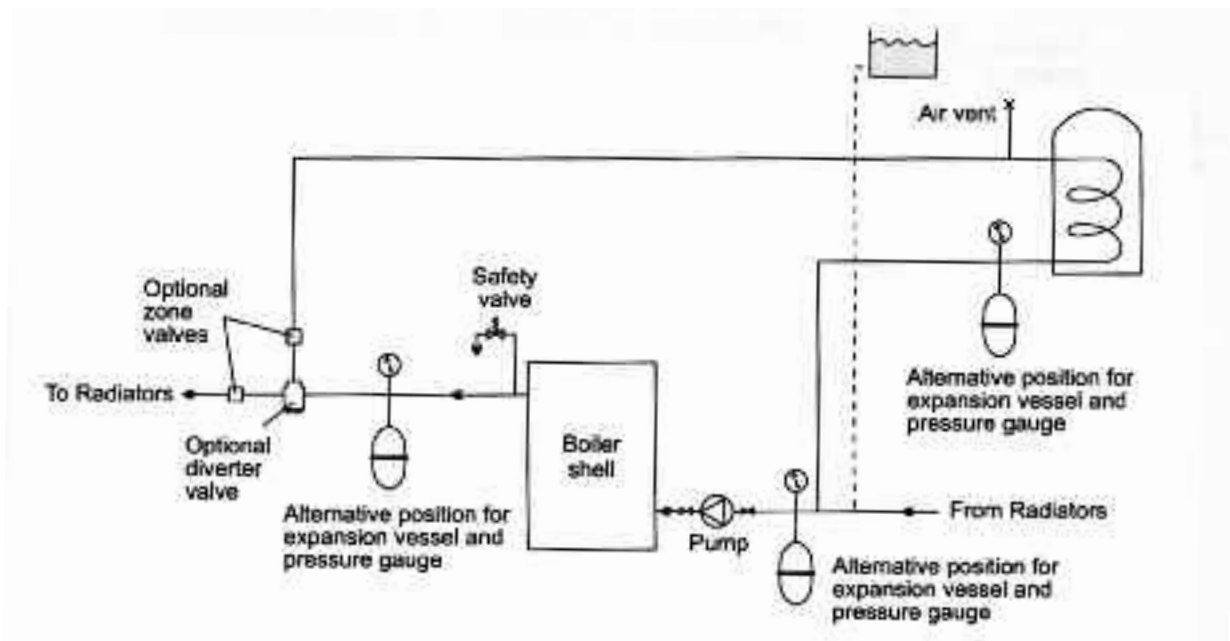

Fig. 15 - Sealed system



4.1 Unpack the boiler

Kitchen models

- 1 Carefully remove the packaging from the boiler and remove it from the transit pallet.
- 2 Open the boiler door (open from the right hand side) and remove the literature pack.

Boiler House models

- 1 Carefully remove the packaging from the boiler. The literature pack is supplied on top of the boiler.
- 2 Unpack the burner. The pack contains the burner and combined boiler control/overheat thermostat.

Refer to section 3.8 to fit a conventional flue.

Note: Depending which model is used, the hole to be cut in the wall for the flue is offset to either the left or right of the boiler centre line as shown below.

4.2 Prepare the wall

See Figs 16 and 17

If the boiler is to be used with a balanced flue, make the hole in the wall for the flue as shown in Figs. 16 (low level flue) or Figs. 17 (high level flue).

Note: Dimensions A and B given in Figs. 16 and 17 include clearance for fitting.

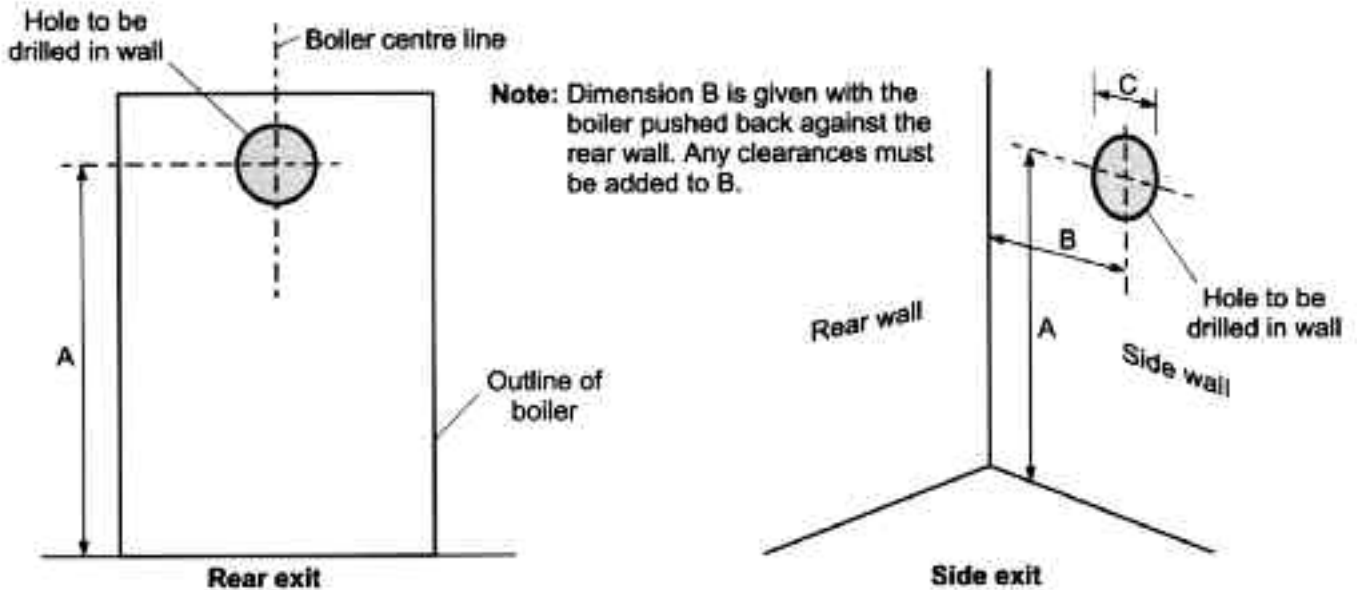

Model	Dimension (mm)		
	A	B	C
Kitchen & System models - 70/90	756	125	127
Kitchen & System models - 90/140	950	130	155
Kitchen models - 140/160, 160/200	1065	155	155
Boiler House models - 70/90	754	150	127
Boiler House models - 90/140	948	130	155
Boiler House models - 140/160, 160/200	1063	155	155

Fig. 16 - Concentric low level balanced flue

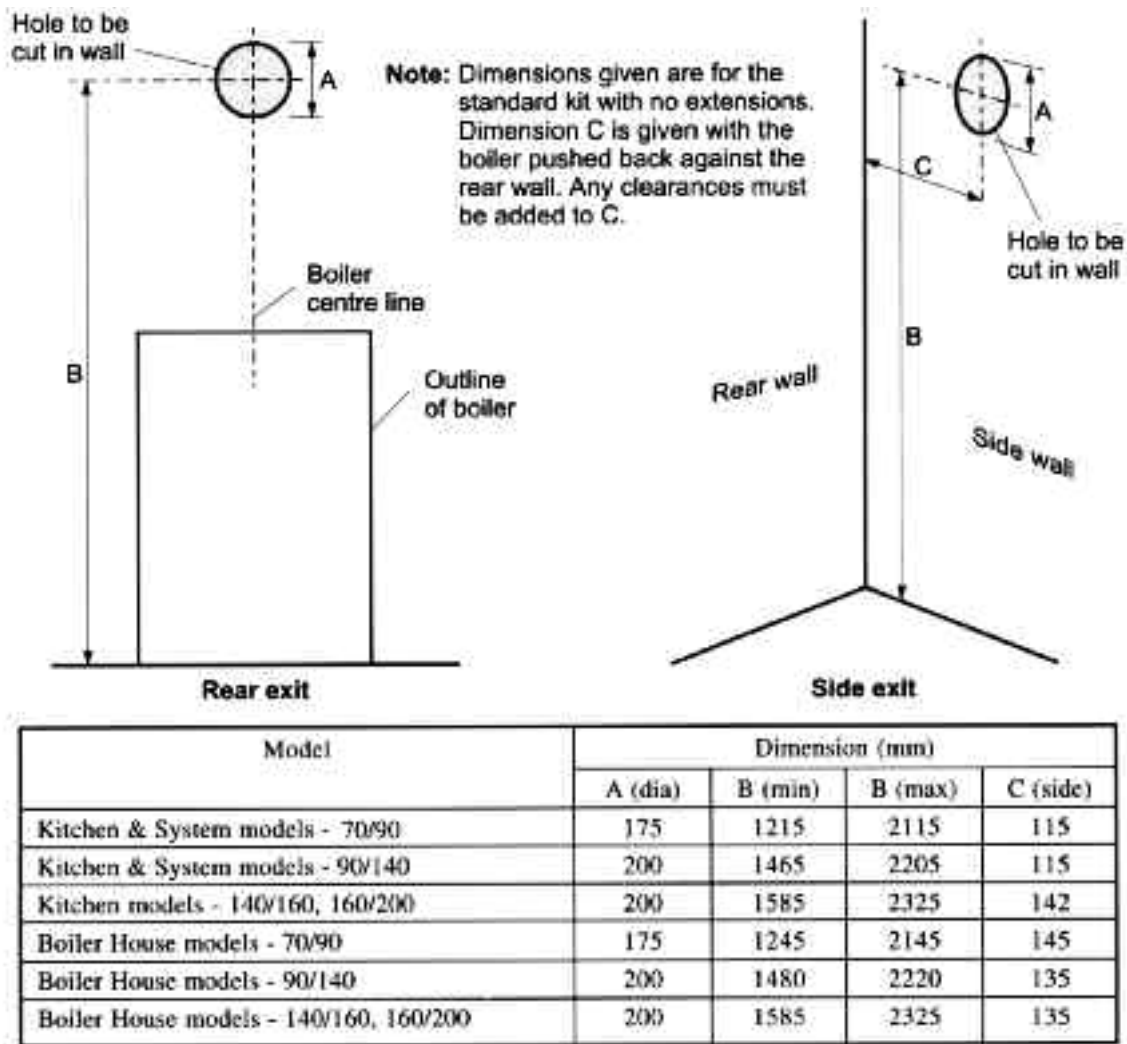

Fig. 17 - High level balanced flue

4.3 High level and Vertical balanced flue

Fitting instructions for the high level balanced flue and vertical balanced flue are supplied with the flue kits.

Adjustable sections: The adjustable extensions are telescopic. The wall terminal section is adjustable and is suitable for a wall thickness of 215 mm to 450 mm. Simply adjust to the required length using a twisting motion. The outer pipes **must** overlap by a minimum of 25 mm.

Extensions: The vertical height and horizontal length of the flue may also be increased using extensions. The extensions are available in fixed lengths of 225 mm, 450 mm and 950 mm. An adjustable extension (275 - 450 mm) is also available.

Bends: 45° bends are available and may be used to create an offset or deviation in the flue system. The distance between the bends should be kept as short as possible with a maximum length of 950 mm.

The equivalent flue length of each elbow is approximately one meter. Only two bends should be used.

Note: The overall assembled flue length should not exceed 4.0 metres top of the boiler to the end of the terminal.

Accessories available:

- Extension 225 mm
- Extension 450 mm
- Extension 950 mm
- Adjustable extension 275 - 450 mm
- 145° bend
- Wall bracket

Note: Flue sections cannot be cut.



4.4 Make the water connections

- 1 Fit the thermostat pocket (supplied with the burner) into one of the tappings on the top of the boiler – If both heating flow and return connections are on one side, position the pocket on **that** side. Use a small amount of jointing compound on the threads.

Note: Boiler House models - Use the thermostat pocket supplied with the boiler/overheat thermostat assembly.

Plug the other connection using the 1/2" BSP plug supplied with the boiler.

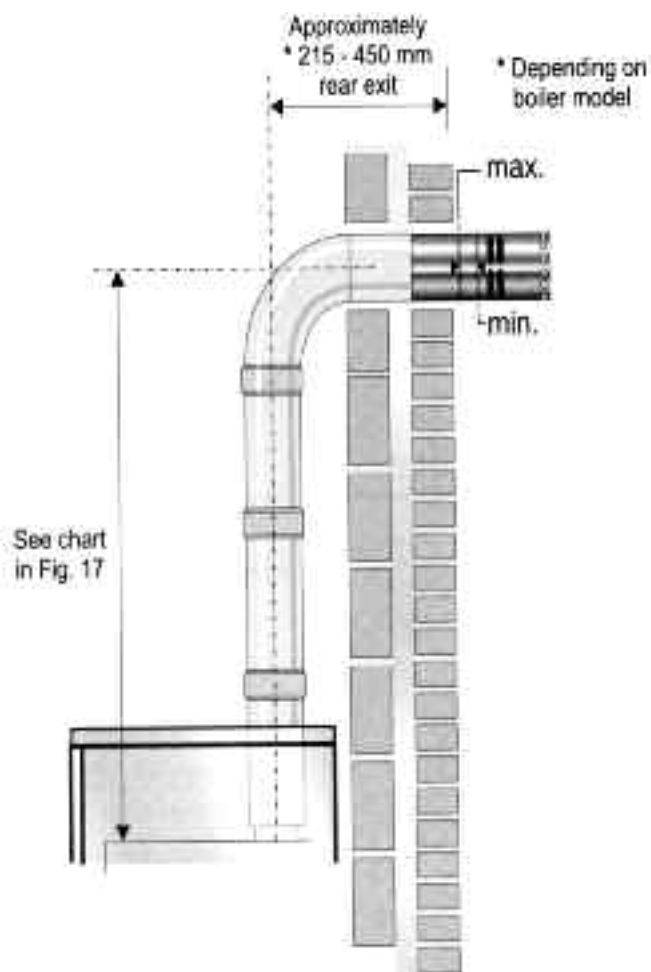

Fig. 18 - High level balanced flue

- 2 Fit any elbows, bushes etc. to the water connections before placing the boiler in position if access will be restricted.

Note: If the boiler is to be positioned against a side wall, the water connections may be taken from one side only, (see paragraph 1 for thermostat pocket position).

- 3 Ensure that all the plastic caps have been removed from the boiler connections.
- 4 Fit the drain cock (supplied), in the bottom right hand connection on the front of the boiler (1/2" BSP).
- 5 Plug all connections not to be used and carefully manoeuvre the boiler into position.
- 6 **Balanced flue models** - Do not make any water connections at this stage.
- 7 **Conventional flue models only** - Complete the water connections and fill the water system. Check for leaks, rectifying where necessary.

4.5 Fit the burner

Kitchen models are supplied with the burner fitted. To fit the burner to a Boiler House model proceed as follows:

Riello RDB burner - see fig. 19

- 1 Remove and retain the burner fixing nut from the stud on the burner fixing flange on the front of the boiler, see Fig. 19. Leave the small nut in position (ensure it is located up against the mounting flange).

Note: Do **not** remove the fixing flange from the boiler.

- 2 Check that the 'O' ring is in position (around the collar of the burner combustion head). Position the burner on the boiler by sliding the combustion head into the mounting flange on the boiler. With the burner level and correctly located over the fixing stud, secure it in position using the nut previously removed.
- 3 **Balanced flue** - Remove the air intake cover from the burner and fit the air tube spigot using the gasket and screws supplied. See Fig. 21. Fit the air tube over the air tube spigot and secure it in position using the clamp supplied.

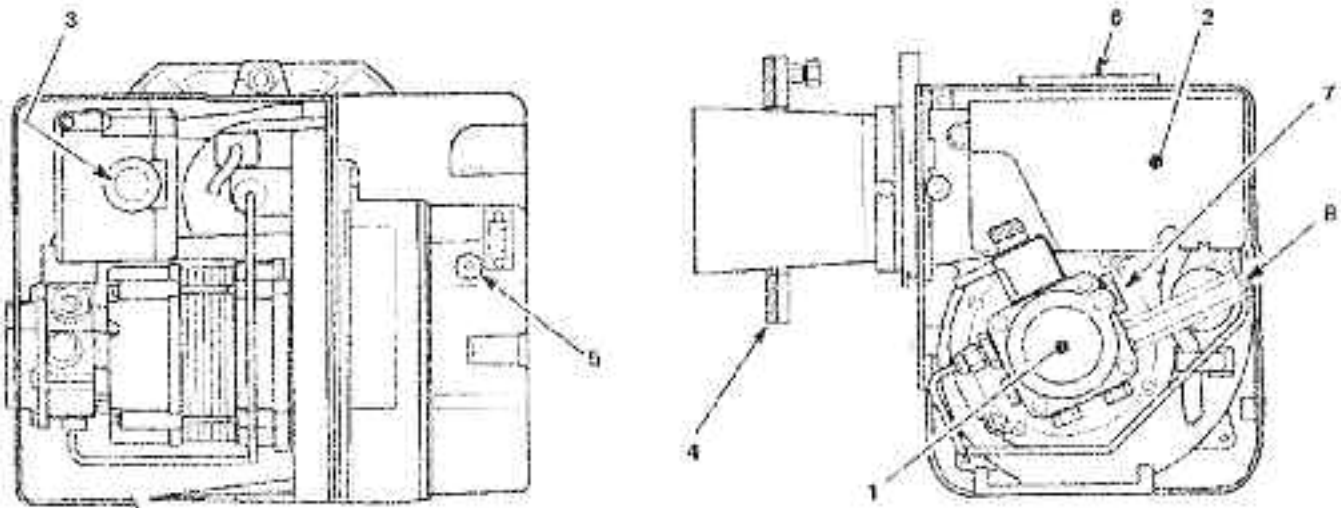

Fig. 19 - Riello RDB burner components

- | | |
|--|--|
| <ul style="list-style-type: none"> 1 Pump 2 Control box 3 Reset button with lock-out lamp 4 Flange with gasket (do not remove from boiler) | <ul style="list-style-type: none"> 5 Air damper adjustment screw 6 Air supply tube connection (balanced flue) 7 Pump pressure adjustment screw 8 Pressure gauge connection |
|--|--|

EOGB Sterling 90 burner - see Fig. 31

- 1 Position the burner gasket over the base of the combustion head and insert the burner mounting bolt so that it passes through the burner lug. Mount the burner assembly so that the combustion head is inside the combustion chamber. Ensure

that the burner gasket remains in position on the face of the burner mounting flange.

- 2 Tighten the single mounting bolt so that the burner is securely attached to the boiler mounting flange.

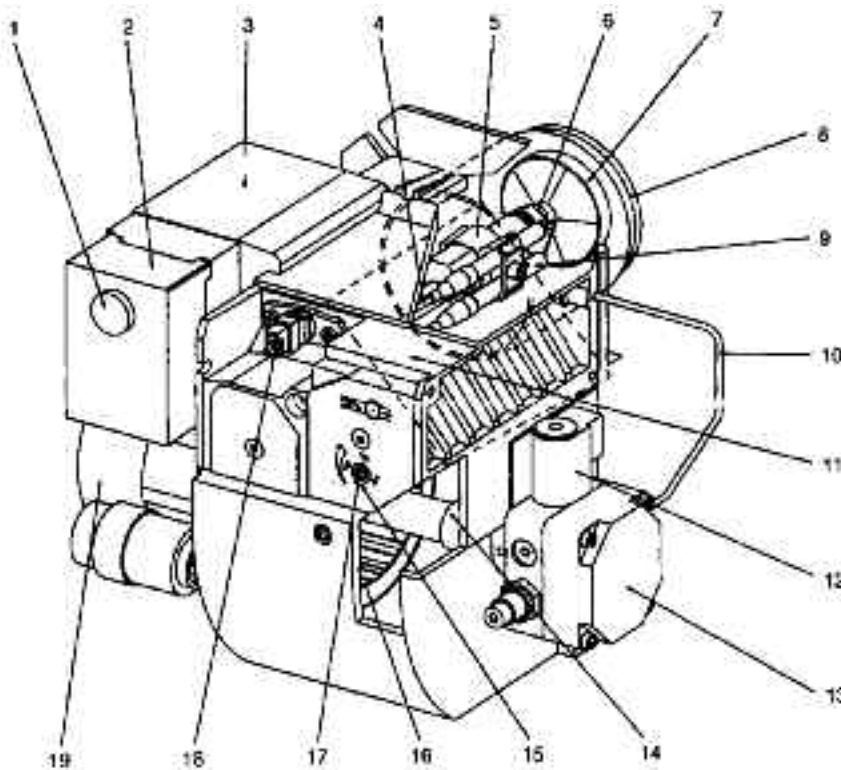

- 1 Lock-out lamp and reset button
- 2 Control Box
- 3 Ignition transformer
- 4 Ignition cables
- 5 Nozzle assembly
- 6 Nozzle
- 7 Diffuser plate
- 8 Combustion head
- 9 Ignition electrodes
- 10 Connecting pipe
- 11 Air dampr
- 12 Solenoid valve
- 13 Pump
- 14 Drive coupling
- 15 Air dampr indicator (under cover plate)
- 16 Fan wheel
- 17 Air damper adjustment (under cover plate)
- 18 Photocell (under cover plate)
- 19 Motor
- 20 Main burner assembly to front assembly fixing bolt
- 21 Nozzle adjustment (under cover plate)

Fig. 20– EOGB Sterling 90 Burner components



4.6 Connect the power supply - Kitchen models

If the timer is not fitted, it is recommended that the boiler should be connected to a switched mains power supply from an external timer or control system. Refer to section 8.4 for a typical control system wiring diagrams.

- 1 Lift off the boiler case top panel, if it has not already been removed.
- 2 Carefully uncoil the two thermostat capillaries and fit the two thermostat phials into the pocket previously fitted on either the left or right connection on top of the boiler. Ensure that the phials are fully inserted and take care not to damage or kink the capillaries.
- 3 Remove the wiring cover and open the cable clamp. Route the supply cable through the hole in the rear panel (using the grommet supplied) up to control panel, pass it through the cable clamp and connect to the boiler terminal block (refer to Fig 33 or 34).

Note: Ensure that the route and length of the cable is such that the boiler front cover plate can be easily removed without disconnecting the supply cable from the terminal block.

- 4 Secure the cable in the cable clamp.
- 5 Place the wiring cover in position over the terminal block, taking care not to trap any wires and secure in position with the two M4 screws provided.
- 6 Ensure that all external wiring is adequately supported.

Do not switch on the electricity supply at this stage.

4.7 Connect the power supply - Boiler House models

It is recommended that the boiler should be connected to a switched mains power supply from an external timer or control system.

- 1 Position the thermostat phials of the combined boiler/overheat thermostat in the thermostat pocket on the front of the boiler. Push the assembly fully home onto the pocket, with the cable entries to the bottom and secure in position by tightening the two fixing screws.
- 2 Undo the three screws securing the combined boiler/overheat thermostat cover and lift off the cover.
- 3 Withdraw the cable support bushes from the cover. Pass the burner supply cable through one of the bushes and connect it to the boiler (control)

thermostat (refer to Fig. 56) as follows:-

Brown to terminal 1 on the control thermostat
Green/Yellow to the earth terminal, marked \equiv , on the control thermostat.

- 4 Pass a switched mains power supply through the other cable support bush and connect it to the overheat thermostat (refer to Fig. 34) as follows:-

Switched live (brown) to terminal C on the overheat thermostat

Earth (green/yellow) and earth fly lead from casing to the earth terminal, marked \equiv , on the overheat thermostat

The Blue (neutral) wire from the burner supply must be linked to the incoming neutral of switched mains supply using a single connector (not supplied).

DO NOT connect the neutral wires to either of the two thermostats.

- 5 Connect a link between terminal 2 on the overheat thermostat and terminal C on the control thermostat.
- 6 **There are no connections to terminal 1 on the overheat thermostat and terminal 2 on the control thermostat.**
- 7 Position the support bushes so as not to strain the connections when the cover is replaced. Place the cover in position locating the bushes at the same time.

Note: It may be necessary to rotate the thermostat knob to engage it on the operating spindle as the cover is replaced.

- 8 Secure the cover in position by tightening the three screws. Tighten the cable support bush nuts to secure the cables.
- 9 Ensure that all external wiring is adequately supported.

Do not switch on the electricity supply at this stage.

4.9 Connect the fuel supply

See Fig. 6 or 8

If a two pipe system is to be used refer to section 3.10.

- 1 Remove the oil inlet plug from the fuel pump and connect the elbow of the flexible fuel line supplied with the boiler.
- 2 Connect the flexible pipe to the rigid supply using the adaptor supplied. For Kitchen models the supply enters through one of the holes at the bottom of the case sides or the back panel.



Refer to Figs. 21 or 21a for boiler controls

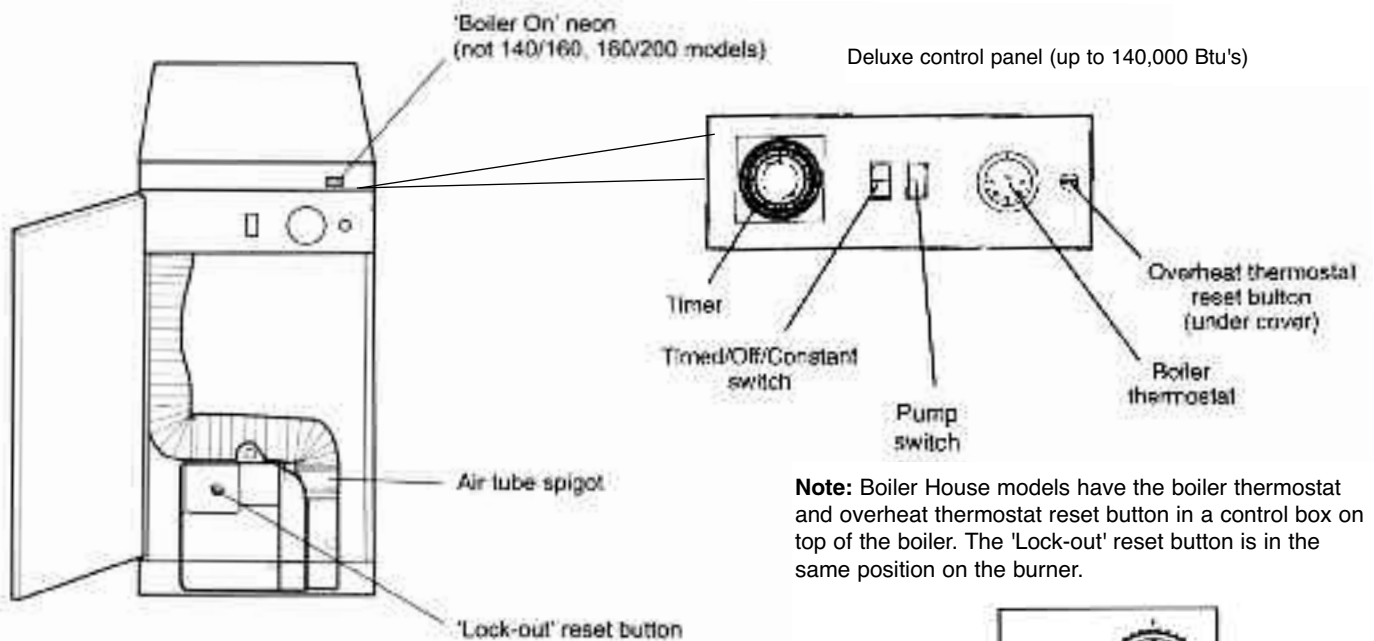

Fig 21

It is important that the following commissioning procedure is carried out to ensure safe and efficient operation of the boiler.

If the boiler output is to be adjusted from that which is factory set, refer to section 1.2 or 1.3 for the required settings, section 7.4 for burner head/nozzle change instructions and Fig. 39 to 43 for baffle adjustment as appropriate.

Note: Check that the baffles are in position and that the cleaning cover is correctly fitted and a good seal made.

- 1 Check that the water system has been vented (and pressurised if sealed system) and there are no leaks.
- 2 Check that all fuel line valves are open.
- 3 Remove the plastic burner cover (two screws) if it was not previously removed. To gain access on Kitchen models, it may be necessary to remove the grey plinth - loosen the screw securing the right hand side of the plinth, then withdraw the plinth forward from the right and away from the case.
- 4 Connect a combined vent manifold and pressure gauge to the pressure gauge connection port on the oil pump. See Fig. 6 or 8. Open the vent screw on your vent manifold to vent the supply while the pump is running.

Note: Boiler House models have the boiler thermostat and overheat thermostat reset button in a control box on top of the boiler. The 'Lock-out' reset button is in the same position on the burner.

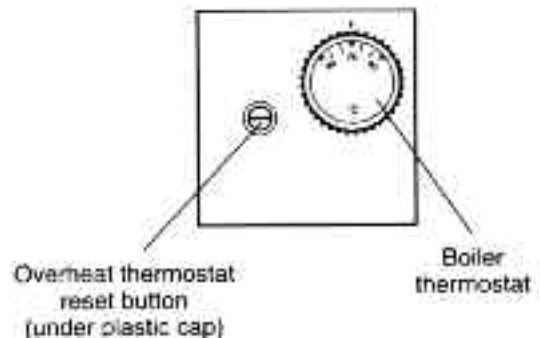

Combined Boiler/Overheat thermostat of the Boiler House models

Fig 21a - Boiler House models

- 5 Set the boiler On/Off switch to Off (Kitchen models only). Check that all system controls are calling for heat and turn the boiler thermostat to maximum. Switch on the electricity supply.

Note: Boiler House models will start as soon as the electricity supply to the boiler is switched on.

- 6 Set the boiler On/Off switch to On (Kitchen models only). The burner fan should start and the burner should light within about 20 seconds. If the burner does not light and the 'Lock-out' reset button lights, wait for about 45 seconds then press the reset button to restart the ignition process. This procedure may have to be repeated several times during first lighting.



- 7 With the burner alight, check the fuel pressure. Refer to the Technical Information, sections 2.2 and 2.3. Adjust the pressure if necessary - see Fig. 6 or 8. Note that the 'Boiler On' neon lights when the boiler is switched on, but does not necessarily indicate the burner is firing. (140/160 and 160/200 models do not have a 'Boiler On' neon).
- 8 Operate the boiler until it reaches normal operating temperature. Check oil supply / return pipe for leaks, rectifying where necessary.
- 9 With the burner alight, re-check the fuel pressure and re-adjust if necessary. Turn the burner off, remove the pressure gauge and replace the plug in the pump.
- 10
 - a Having ensured that there are no oil leaks, replace the burner cover. Ensure the flexible air tube is connected to the burner (balanced flue models).
 - b Replace the plinth to the Kitchen model (if removed). Locate the left hand side over the locating stud and locate the slot in the right hand side over the screw previously loosened. Tighten the fixing screw.
- 11 Relight the boiler and allow it to run for 20 minutes then check the following:-
CO₂ level, Flue gas temperature and Smoke Number. Refer to the Technical Information in sections 2.2 and 2.3.
A flue gas sampling test point is provided in the cleaning cover on top of the boiler.

Note: The flue gas temperature measured using the cleaning door test point is approximately 25°C higher than at the flue.

- 12 Check the smoke number, if satisfactory check the CO₂.

Riello RDB burner: Use the hexagonal key supplied to adjust the burner air damper (See Fig. 19) as required. Turning the screw anti-clockwise closes the damper and increases CO₂ level, turning the screw clockwise opens the damper and reduces CO₂ level.

EOGB Sterling 90 burner: Adjust the burner air regulator, to gain access remove the controls cover plate, see Fig. 20. Turning the adjustment screw (4 mm allen key) anticlockwise (towards -) closes the damper and increases CO₂ level, turning the adjustment screw clockwise (toward +) opens the damper and reduces CO₂ level. Replace the cover plate.

Re-check the smoke number if the air damper has been moved.

Under no circumstances must the smoke number be above 1.

A suitable position for the air damper is one which gives 1% less CO₂ than that which has a smoke number of 1.

Note: It is important that the air damper is correctly set.

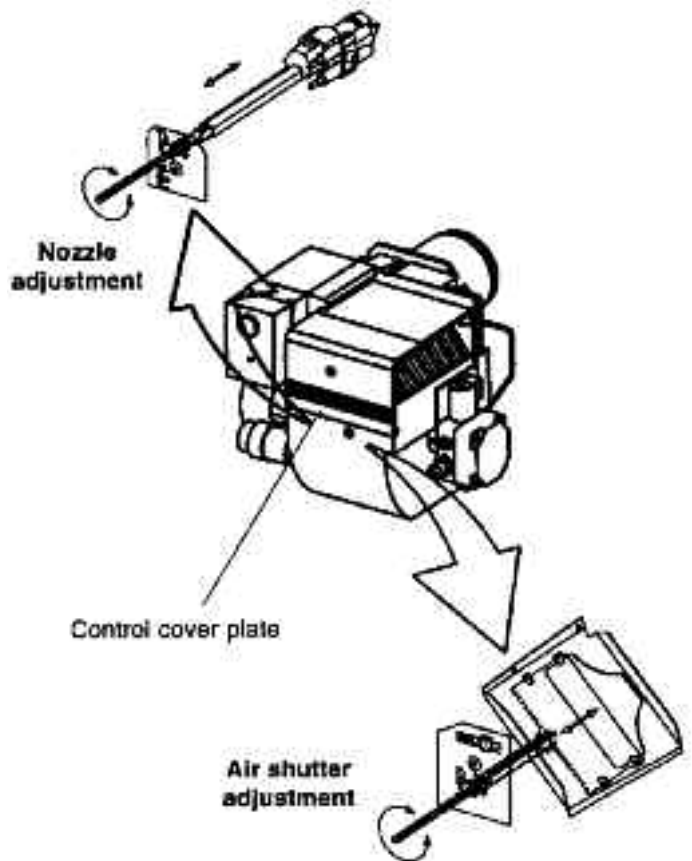

Fig 22 – EOGB Sterling 90 burner

- 13 Check the flue gas temperature.
- 14 Check the boiler overheat thermostat by removing the boiler thermostat phial (the shorter one for Kitchen models) from the pocket in the front of the boiler shell. The boiler should switch off on the overheat thermostat. Replace the phial. Unscrew and remove the reset button cover, press the reset button and replace the cover.
- 15 Replace the case top.
- 16 When the boiler has been adjusted and is running satisfactorily, balance the central heating system by adjusting the radiator lock shield valves. Start with the radiator nearest the boiler and adjust the valves to achieve the temperature drop across each radiator.
- 17 Switch off the boiler.



18 With the hot water system hot, check again for leaks, rectifying where necessary. Drain the system while it is hot to complete the flushing process. Refill and vent (and pressurise if a sealed system) the system.

19 A suitable central heating system inhibitor must be added to protect the system against the effect of corrosion.

20 Close the front door panel.

Note: After commissioning the boiler you should complete the Commissioning Report on page 2 of these instructions.

If the boiler is to be left in service with the User, set the controls, timer (If optional programmer is fitted, see instructions supplied in kit) and room thermostat (if fitted) to the User's requirements then refer to section 6.

If the boiler is not to be handed over immediately, close the boiler fuel supply valve and switch off the electricity supply.

If there is any possibility of the boiler being left during frost conditions, then the boiler and system should be drained.

IMPORTANT NOTE:

To allow the boiler to be commissioned and serviced correctly a combustion test point is provided on the top of the boiler.

The CO₂, flue gas temperature and smoke test may all be carried out using this test point. The test point is not suitable for measuring boiler efficiency or conventional flue draught.

When using the test point on the cleaning cover note that the flue gas temperature reading will be considerably higher than that measured in the flue thus resulting in an inaccurate efficiency reading. To obtain an accurate flue gas temperature and efficiency, the reading can only be measured outside through the low level flue terminal. For high level and vertical balanced flues the reading may be taken from the flue kit test point provided. Refer to section 2.2 and 2.3.

For conventional flue draught measurement and efficiency a hole must be drilled in the conventional flue pipe. Seal the hole after testing.

6 - INFORMATION FOR THE USER

The User must be advised (and demonstrated if necessary) of the following important points:-

- 1 How to light and turn off the boiler and how to operate the system controls.
- 2 The precautions necessary to prevent damage to the central heating system and to the building, in the event of the boiler not being in operation during frost conditions.
- 3 The importance of servicing the boiler to ensure safe and efficient operation. This should normally only be required once a year.
- 4 The type of fuel used.
- 5 That any servicing or replacement of parts must only be carried out by a suitably qualified engineer.
- 6 Ensure that the boiler controls and room thermostat (if fitted) are set to the User's requirements.
- 7 If the boiler is used on a sealed heating system, tell the User the system pressure and show them the position of the safety valve discharge pipe.
- 8 Show the User how to reset the overheat thermostat and how to restart the boiler if it goes to 'Lock-out'.

Leave this Instruction Manual with the User.



To ensure efficient operation of the boiler it is recommended that it is checked and serviced as necessary at regular intervals. The frequency of servicing will depend upon the particular installation conditions and usage, but in general once per year should be adequate.

Servicing and replacement of parts must only be carried out by a suitably qualified engineer.

Important: Details of every service should be entered in the Service Log, on page 2 of these instructions. This information may be required to validate the Grant warranty.

IMPORTANT

Before starting any work on the boiler, or fuel supply please read the health and safety information given in section 11 on page 44.

7.1 Important notes prior to servicing

- 1 Check the flue terminal and ensure it is not blocked or damaged.
- 2 Run the boiler and check the operation of its controls
- 3 Ensure that all water/fuel system connections and fittings are sound. Remake any joints and check the tightness of any fittings that may be leaking.
If the boiler is used on a sealed central heating system, check the system pressure. Refill, vent and re-pressurise the system as necessary.
Check the expansion vessel air charge. See section 3.6.
- 4 Check that any ventilation openings are adequate and are clear. See section 3.6.
- 5 Remove any sludge/water from the fuel tank by opening the sludge valve at the lower end of the tank.
- 6 With the fuel supply valve closed, clean/replace the filter element and clean the filter bowl.
- 7 Flexible fuel supply pipes should be inspected annually when the boiler is serviced and replaced every two years. If in doubt replace the pipes.

Warning: Before servicing, set the boiler On/Off switch to OFF (Kitchen/Utility models only), isolate the electricity supply and close the fuel supply valve. Allow the boiler to cool.

The data label on the inside of the case side panel for Kitchen/Utility models or on the front panel for Boiler House models, will indicate the fuel used and nozzle fitted.

7.2 Dismantling prior to servicing

- 1 **Kitchen/Utility models** - Open the case door and remove the grey plinth - loosen the screw securing the right hand side of the plinth inside the case. Withdraw the plinth forward from the right and away from the case.
- 2 If necessary, disconnect the flexible air tube from the burner.
- 3 Remove the burner fixing nut (top of mounting flange) and withdraw the burner.

If required, disconnect the flexible oil pipe(s), use a suitable container to prevent any oil spillage.

Note: If two flexible fuel pipes are connected to the burner, identify (mark if necessary) which is the inlet and return if they are to be disconnected.

7.3 Cleaning the boiler

See Fig. 34

- 1 Remove the four nuts and washers securing the cleaning door and withdraw the door. Take care - it is heavy.
- 2 Remove the baffles as shown in Fig. 23 (baffles shown for 70/90 model). Refer to Figs. 27 to 30 for other baffle configurations.
- 3 Remove all deposits from the baffle plates and all the boiler internal surfaces using a stiff brush and scraper if necessary.
- 4 Check the condition of the flue, clean as necessary.
- 5 Check the condition of the front cleaning door seal, replace if necessary.
- 6 Replace the baffles, ensuring they are correctly fitted. See Fig. 23.
- 7 Replace the front cleaning door, ensuring the seal is in good condition and secure it in position with the four nuts and washers previously removed. Tighten to form a seal.

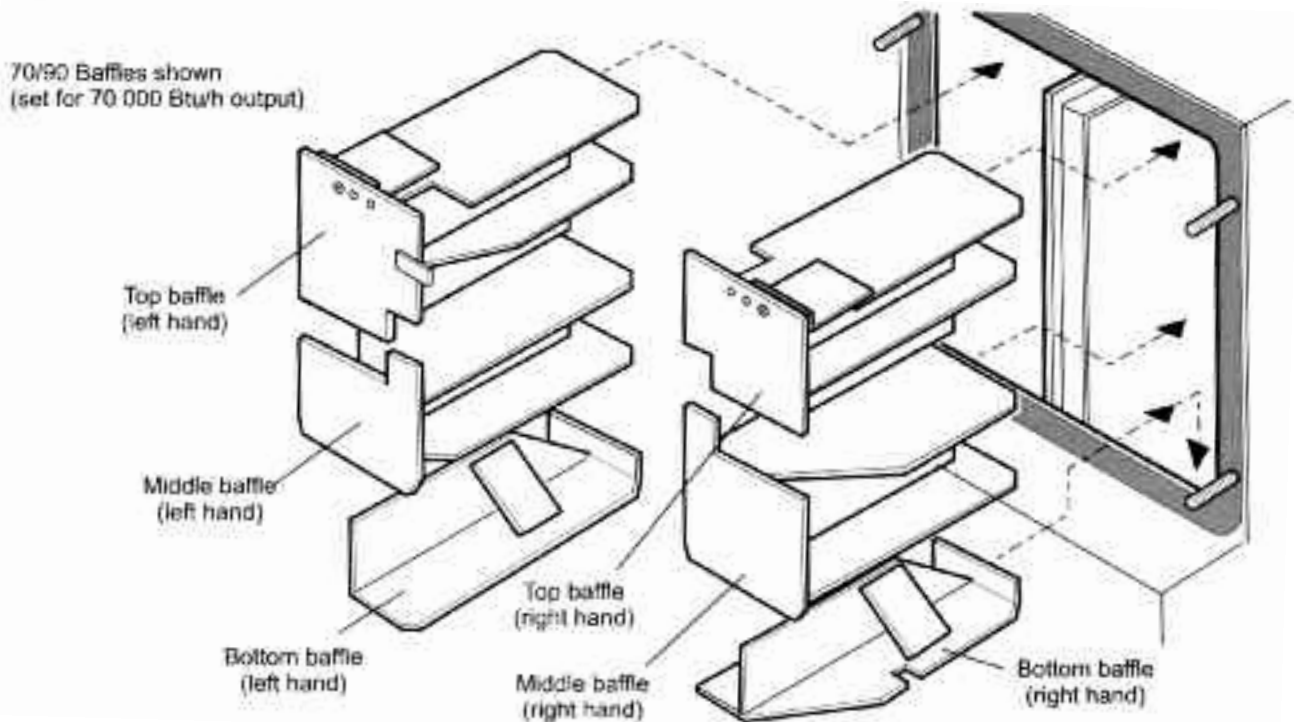

Fig 23

7.4 *Cleaning the burner*

See Section 10.1

- 1 **Combustion head** - Loosen the two screws securing the combustion head and withdraw the head. Clean and replace the combustion head.

EOGB burner - To adjust the nozzle to combustion head position (see Fig. 25), remove the controls cover plate (see Fig. 22) and turn the adjustment screw (4 mm allen key) anticlockwise (towards -) increases the gap, turning the adjustment screw clockwise (towards +) reduces the gap. Replace the cover plate.

- 2 **Inspect the ignition electrodes**

Riello burner - Remove the combustion head.

EOGB burner - Detach the main burner assembly by loosening the 4 mm socket headed bolt (see Fig. 26) and remove it from the front assembly.

Both burners - Loosen the electrode clamp screw and withdraw the electrode assembly. Wipe clean and check for any cracks in the ceramic insulation. Replace if necessary.

Check the electrode settings

Riello burner - Electrode tips approximately 4 mm apart and 3 to 3.5 mm (70/90, 90/140) in front of the nozzle, see Fig. 24.

- 3 **Nozzle** - Check that the nozzle size and type are correct, refer to tables in sections 2.2 or 2.3 and boiler data label. Clean the nozzle with kerosene if necessary.

Do **not** use a pin or piece of wire to clean the nozzle.

Replace the nozzle if a build up of carbon is present.

With the combustion head removed (Riello burner) or the burner assembly split (EOGB burner, see paragraph 2 above), loosen the electrode assembly clamp screw and slide the electrodes away from the nozzle. Remove the nozzle using a good fitting spanner (16 mm). The use of an ill-fitting spanner will damage the nozzle and could lead to an incorrect flame pattern. Always check the electrode settings (and nozzle to combustion head position for EOGB burner) after replacing the nozzle, see Fig. 24 or 25.

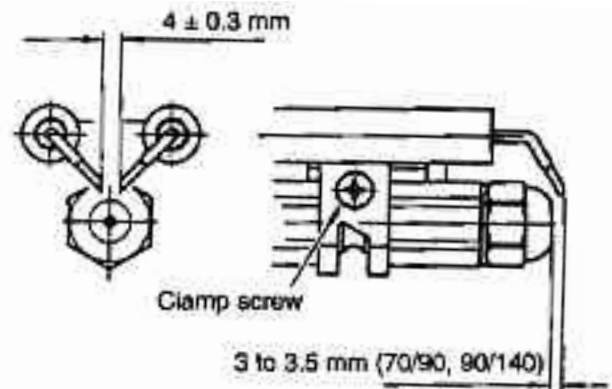

Fig 24 (70/90 & 90/140 RDB shown)

Important: The electrode settings given above MUST be observed.

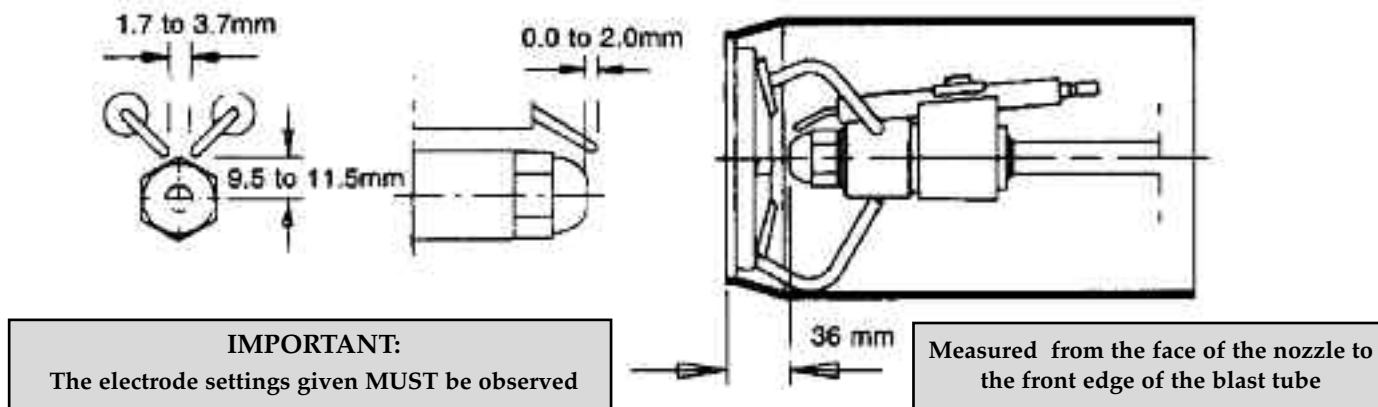

Fig. 25 – EOGB Sterling 90 burner head/electrode settings

4 **Riello burner photocell** - The photocell is a push-fit in the burner body, see Fig. 19. Carefully pull out the photocell to clean.

EOGB burner photocell - Remove the controls cover plate (see Fig. 22) and carefully withdraw the photocell, see Fig. 20).

5. **Riello burner fan** - With the air intake grille or spigot removed, remove the screws securing the fan housing cover (R/H side of burner) and remove the cover. Inspect the fan and housing and clean as necessary. Replace the cover.

EOGB burner fan - The fan wheel and housing are accessible when the main burner and front assemblies are separated.

6 **Pump filter** - With the burner cover removed (Riello burner), remove the four screws securing the pump end cover. Remove the filter and wash in kerosene. Replace the filter and end cover, ensure the 'O' ring is in position.

Re-assemble in reverse order.

To ensure safe and efficient operation of the boiler it is important that re-commissioning is carried out, especially combustion checks (CO₂ level, flue gas temperature and smoke number) after the boiler has been serviced.

Refer to the Commissioning instructions starting on page 29.

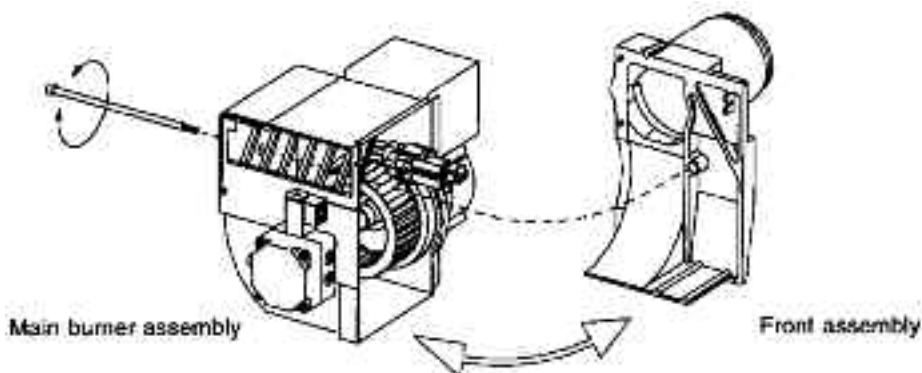
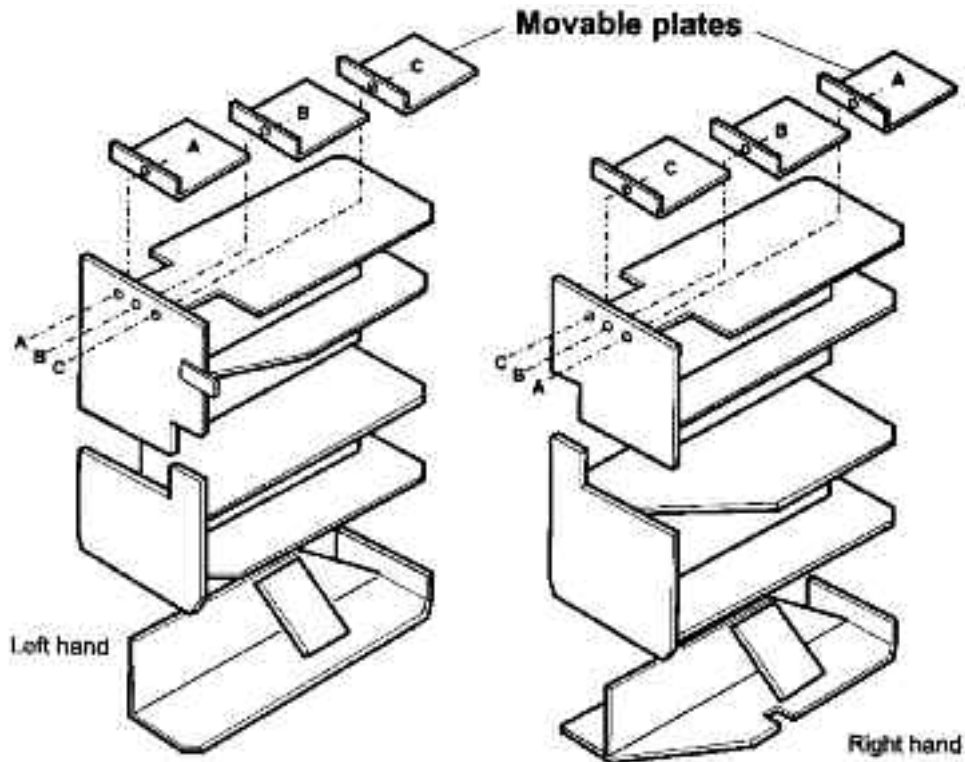
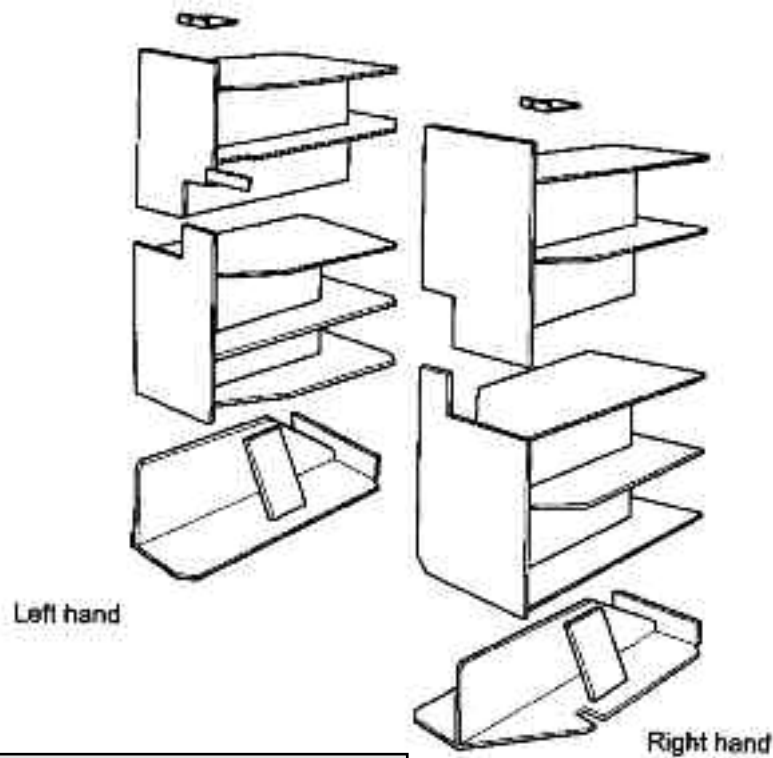

Fig. 26 EOGB Sterling burner



Note: Secure plates in position A for 70 000 Btu/h output
 Secure plates in position B for 80 000 Btu/h output
 Secure plates in position C for 90 000 Btu/h output

Fig. 27 - 70/90 Baffle arrangement



Note: Secure plates in position as shown for 140 000 Btu/h output
 Remove plate completely for 110 000 Btu/h output

Fig. 28 - 90/140 Baffle arrangement

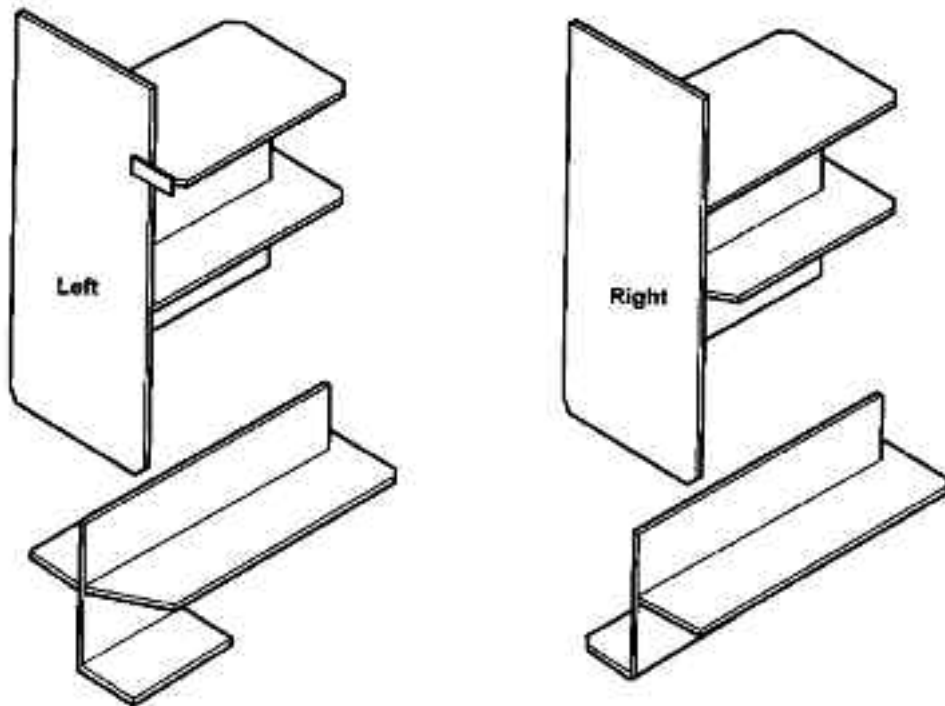

Fig. 29 - 140/160 Baffle arrangement

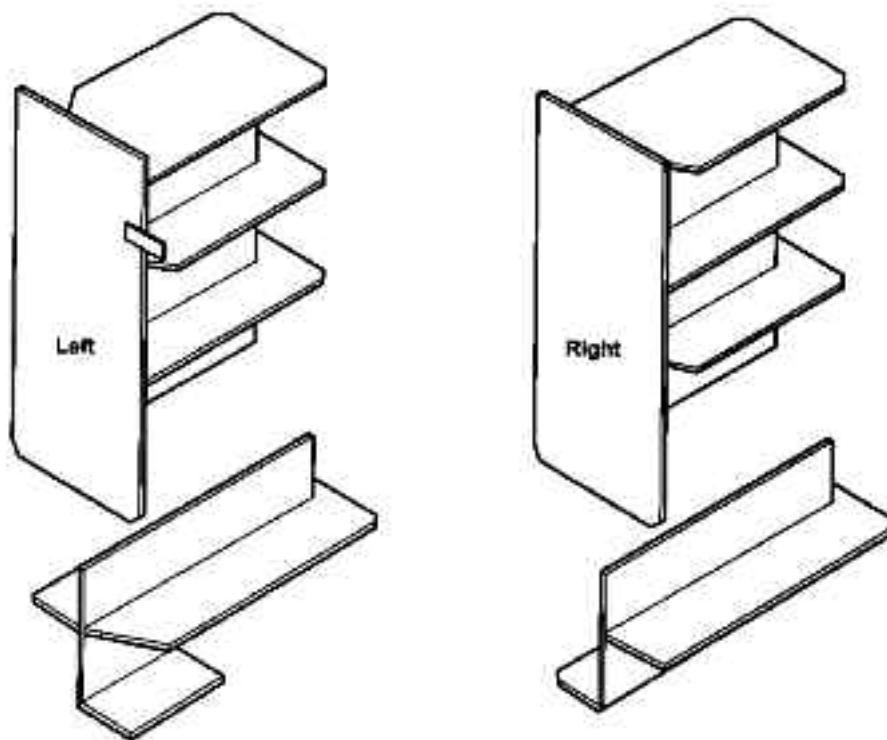
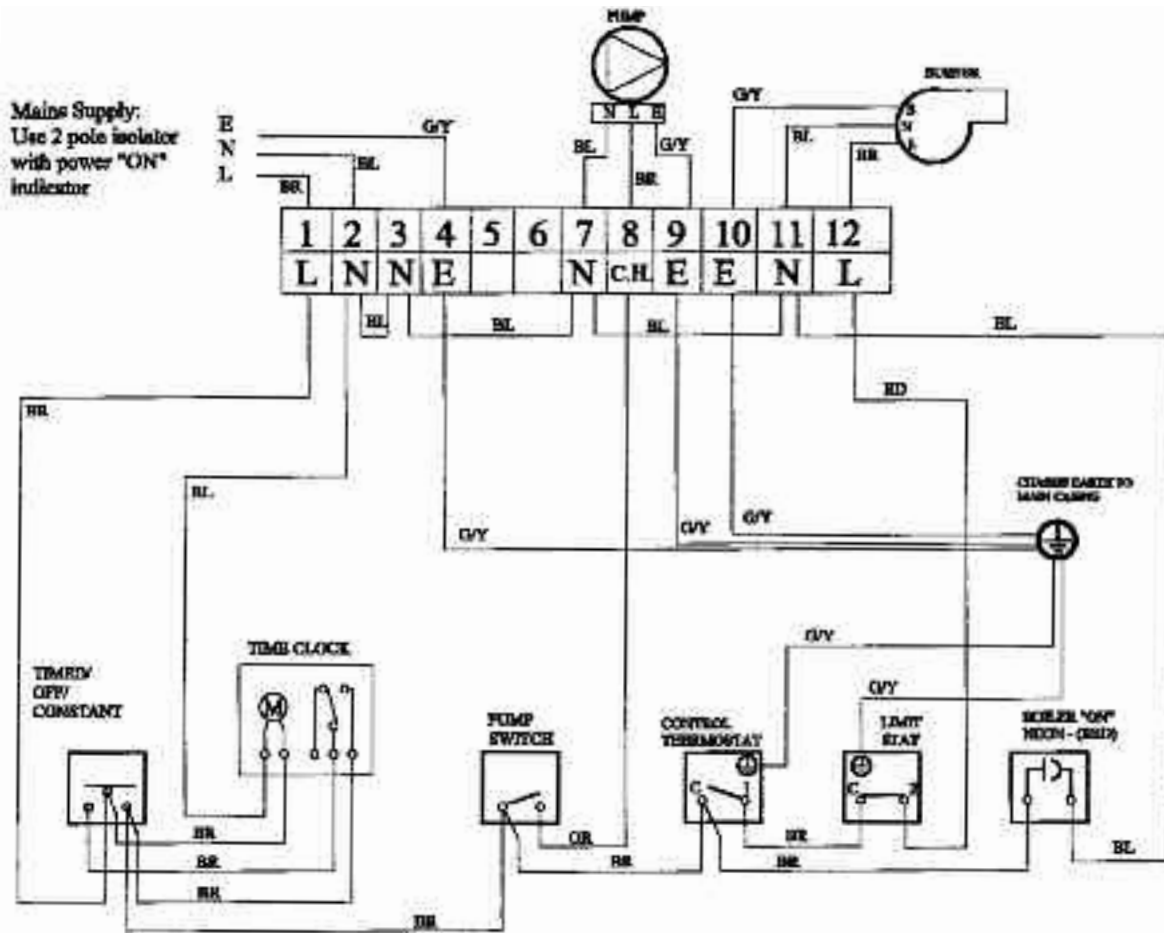

Fig. 30 - 160/200 Baffle arrangement



8.1 Kitchen Boiler Control Panel Wiring Diagram 70/90, 90/140 with Timer fitted



Colour code: BR - Brown, R - Red, BL - Blue, Y - Yellow, G/Y - Green/Yellow, OR - Orange

Fig. 31

8.2 Kitchen Boiler Control Panel Wiring Diagram 70/90, 90/140 without Timer fitted

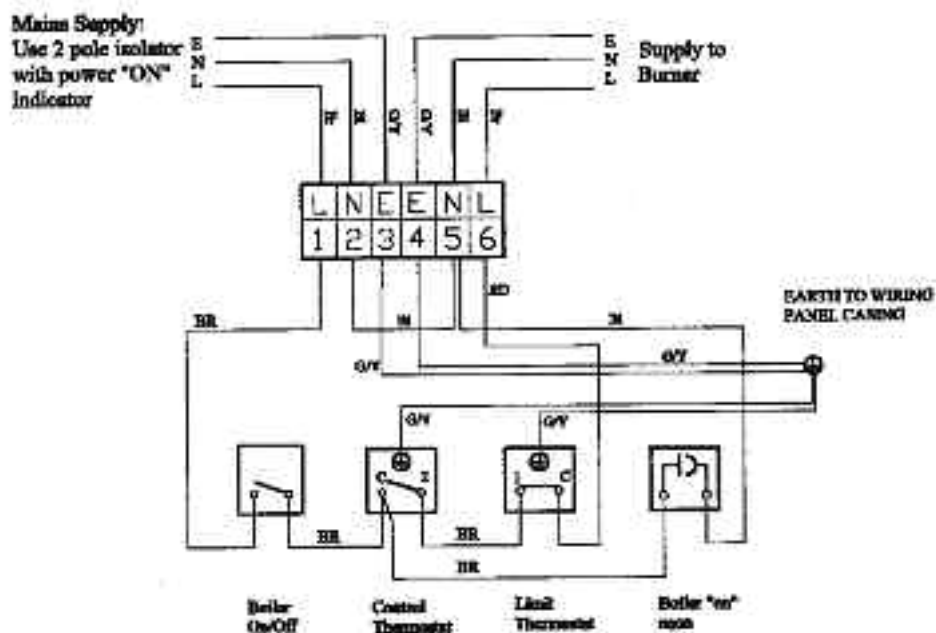

Colour code: BR - Brown, BL - Blue, RD - Red, G/Y - Green/Yellow

Fig. 32



8.3 Kitchen boiler control panel wiring diagram (140/160 and 160/120)

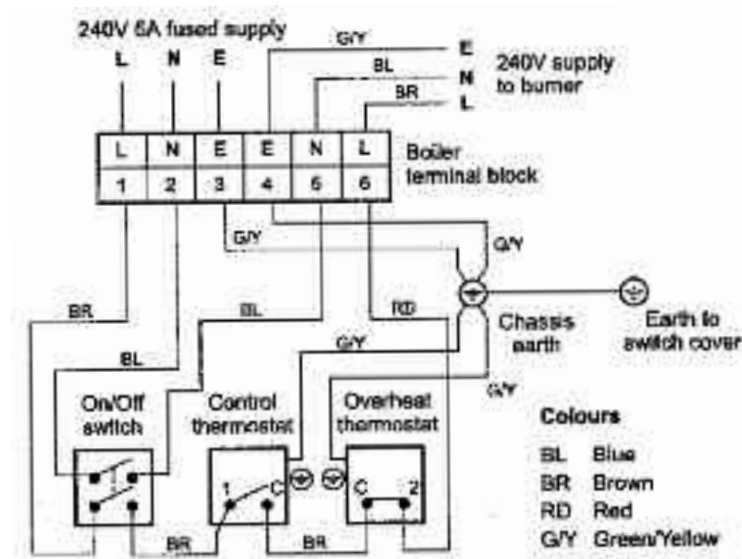

Fig. 33

7.4 Dual thermostat wiring diagram (Boiler house models)

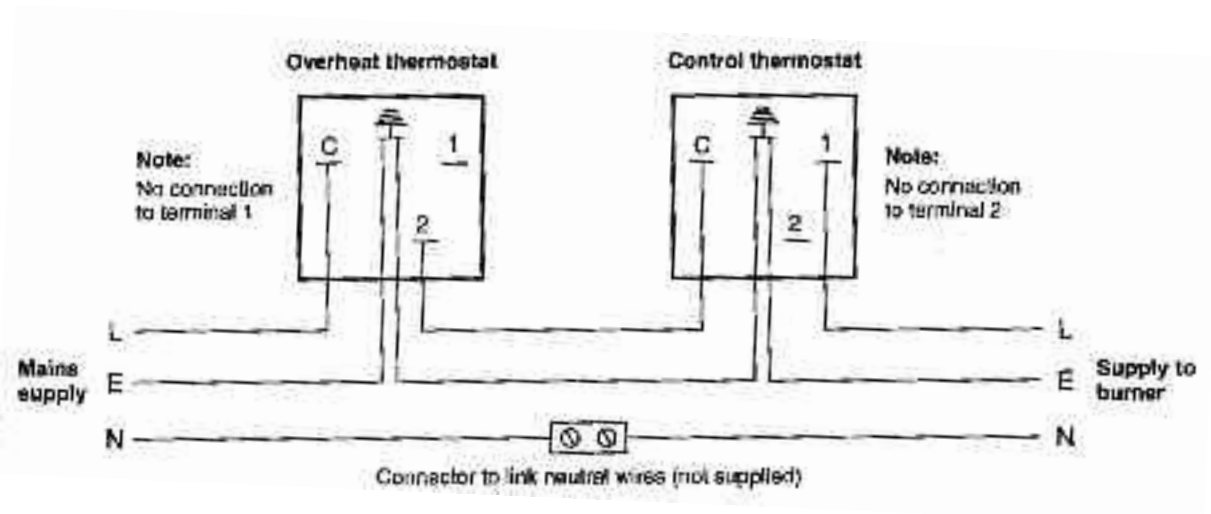
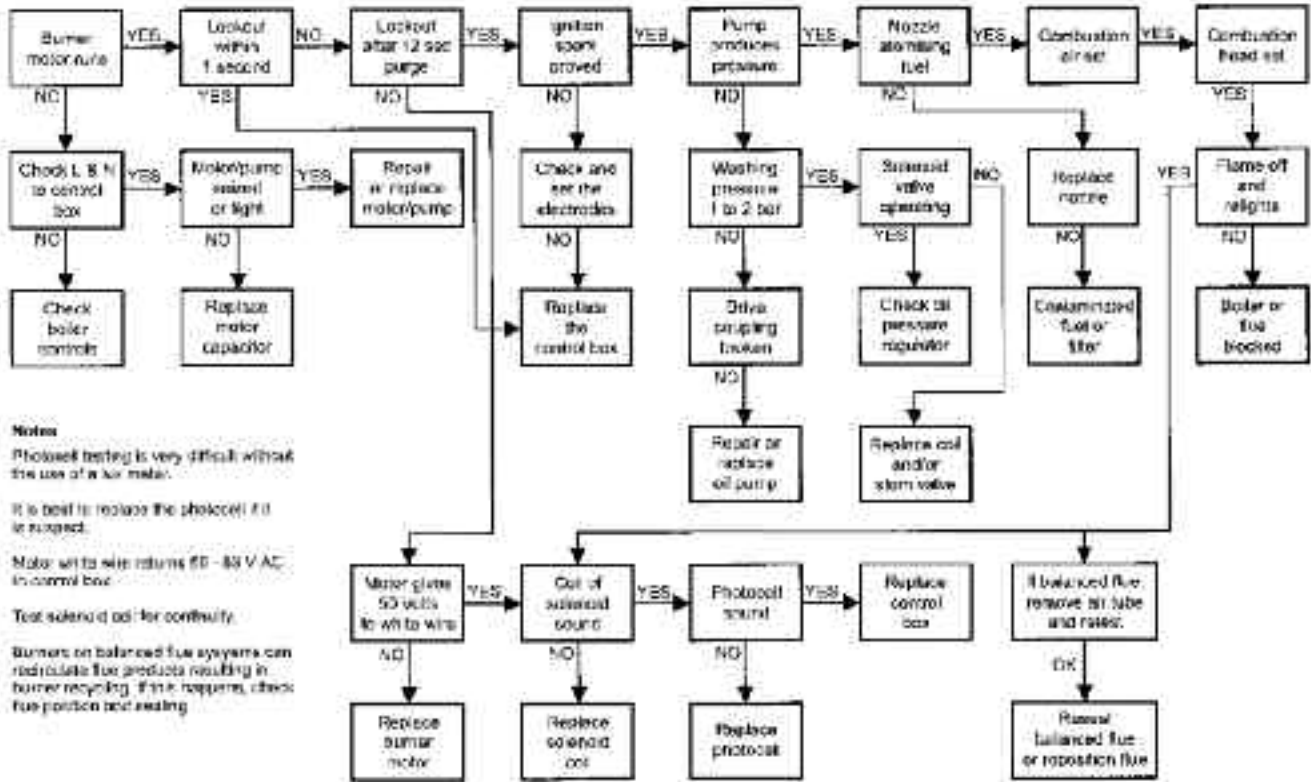

Fig. 34



9.1 Riello RDB burner fault finding





9.2 EOGB Sterling 90 burner fault finding

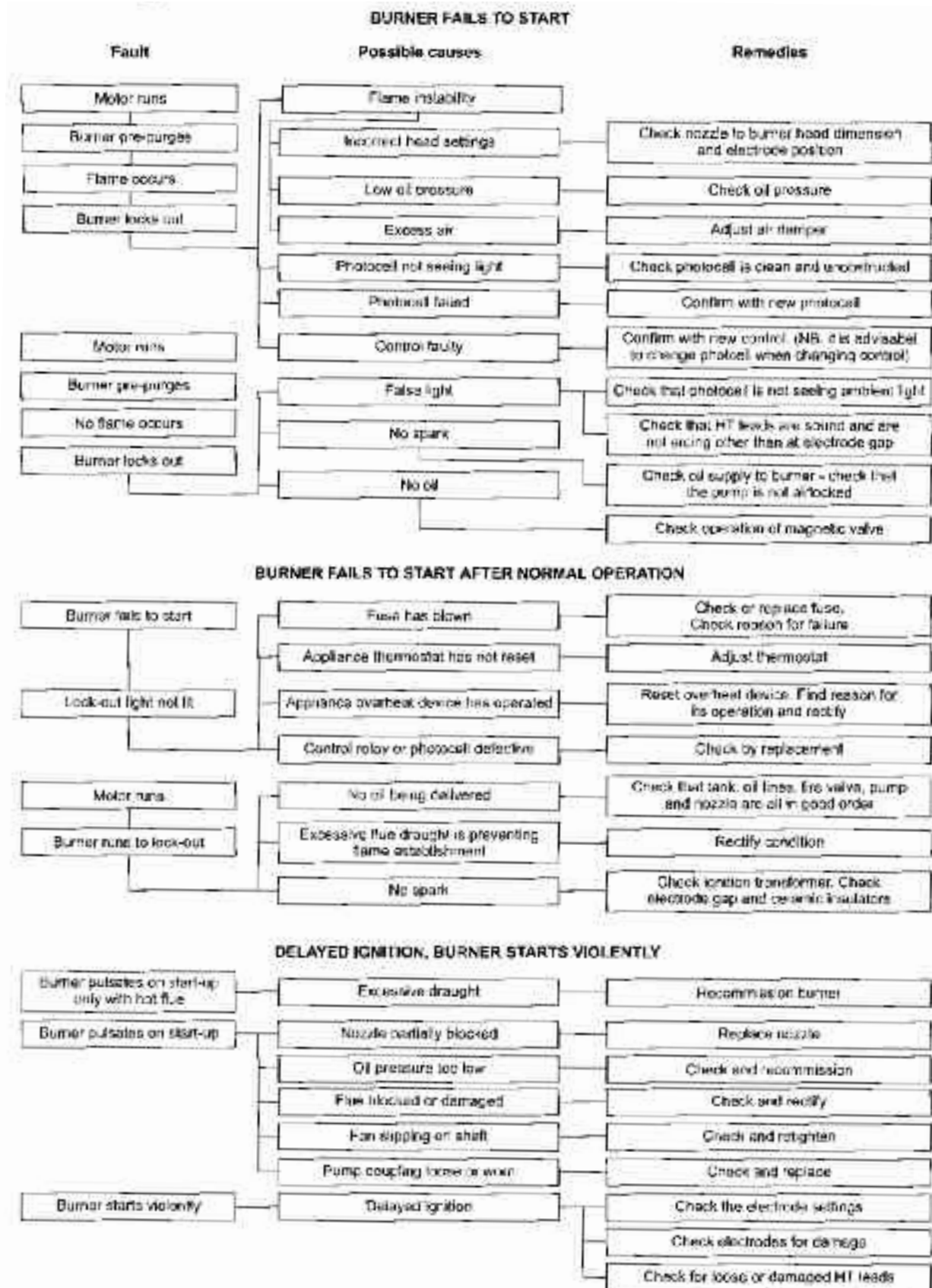



8.3 Boiler fault finding

Warning: Always isolate the electricity supply to the boiler before working on the boiler.

<i>Faults</i>	<i>Remedies</i>
Boiler will not start	
1 No fuel supply	Ensure that an adequate supply of fuel is available and that the fuel supply valve is open. Check the condition of the fuel filter, clean if necessary. Ensure fuel supply is reaching burner and vent pump.
2 No electricity supply.	Ensure electricity supply to the boiler is switched on and that all controls are calling for heat. Ensure that the overheat thermostat has not tripped, reset if necessary. Check that a mains supply is present at the burner terminal block. If not, check the boiler and overheat thermostat.
3 Burner not starting - fuel and electricity supplies present.	Press the reset button on the burner control box if it is lit. Refer to burner fault finding flow diagram.
4 Burner lights but goes to 'lock-out'	If the flame is unstable, check the combustion settings. Refer to burner fault finding flow diagram.
Boiler works but:-	
5 Visible smoke from flue or high smoke number.	Insufficient air supply - check the air damper setting and the condition of the fan. Check room ventilation is adequate, see section 2.6. Check the nozzle size and type. Fuel pressure may be too high - check and adjust.
6 Burner pulsates.	Insufficient air supply - check the air damper setting and the condition of the fan. Check room ventilation is adequate, see section 2.6. Check the nozzle size and type.
7 Flame slow to stabilise during start up.	Insufficient air supply - check the air damper setting and the condition of the fan. Check room ventilation is adequate, see section 2.6. Check the nozzle size and type. Fuel pressure may be too low - check and adjust. Insufficient draught - clean boiler heat exchanger and check condition of flue.
8 Water temperature low.	Undersize nozzle and/or low fuel pressure. Check condition of boiler heat exchanger and clean if necessary. Check the boiler thermostat. Check the combustion settings. Check the condition of the fuel filter.
9 Boiler operating on overheat thermostat.	Faulty boiler thermostat.
10 Fumes and puffing during starting. (conventional flue).	Check the condition of the chimney, ensure it is not blocked and is high enough to produce the required draught. Check that there is an adequate air supply near the burner and that a kitchen fan is not drawing products out of the burner.
11 Oil odours.	Check all fuel line connections, remake as necessary.
12 Combustion fumes smell.	Check boiler cleaning cover and seal are correctly fitted. Check burner is correctly fitted onto flange. Check flue is correctly sealed into flue outlet of boiler.



10. – BURNER SPARE PARTS

10.1 Riello RDB burner - exploded view

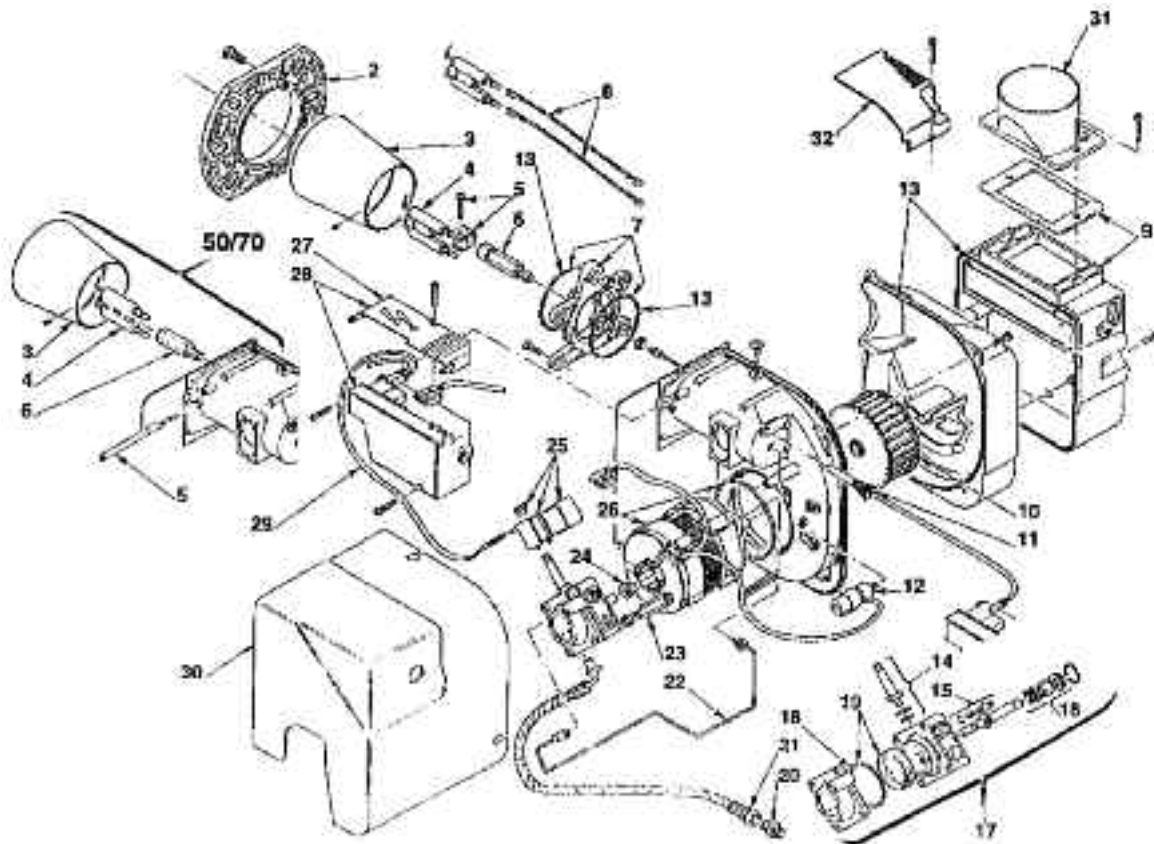

Key No.	Description	Riello Part No.	Grant Part No.	Key No.	Description	Riello Part No.	Grant Part No.
1	Not applicable	-	-	16	Pump seal	3000439	RBS14
2	Flange	3005786	RBS28	17	Pump	3008654	RBS101
3	Combustion head LD2	3008724	RBS126	18	'O' ring	3007162	RBS08
3	Combustion head LD3	3008768	RBS127	19	Filter - 'O' ring	3008653	RBS122
3	Combustion head LD3A	3008769	RBS128	20	Connector	3003602	RBS35
4	Electrode assembly (70/90)	3007513	RBS108	21	Flexible pipe	3007672	RBS36
5	Electrode bracket (70/90)	3006652	RBS29	22	Tube	3008644	RBS113
6	Nozzle holder (50/70)	3008642	RBS111	23	Pressure gauge connector	3008876	RBS138
7	Collar (70/90)	3008643	RBS112	24	Drive coupling	3000443	RBS16
8	High voltage lead	3008794	RBS129	25	Solenoid	3008648	RBS117
9	Air damper assembly	3008647	RBS116	26	Motor	3008650	RBS102
10	Fan	3005708	RBS39	27	Cover	3008649	RBS118
11	Photocell	3008646	RBS115	28	Control box assembly	3008652	RBS103
12	Capacitor 4µF	3007479	RBS107	29	Solenoid lead	3008851	RBS139
13	Seal kit	3008878	RBS140	30	Cover	3008879	RBS141
14	Needle valve	3007852	RBS109	31	Air tube spigot	3062774	RBS143
15	Regulator	3008651	RBS120	32	Air intake cover		RBS142



10.2 EOGB Sterling 90 burner - exploded view

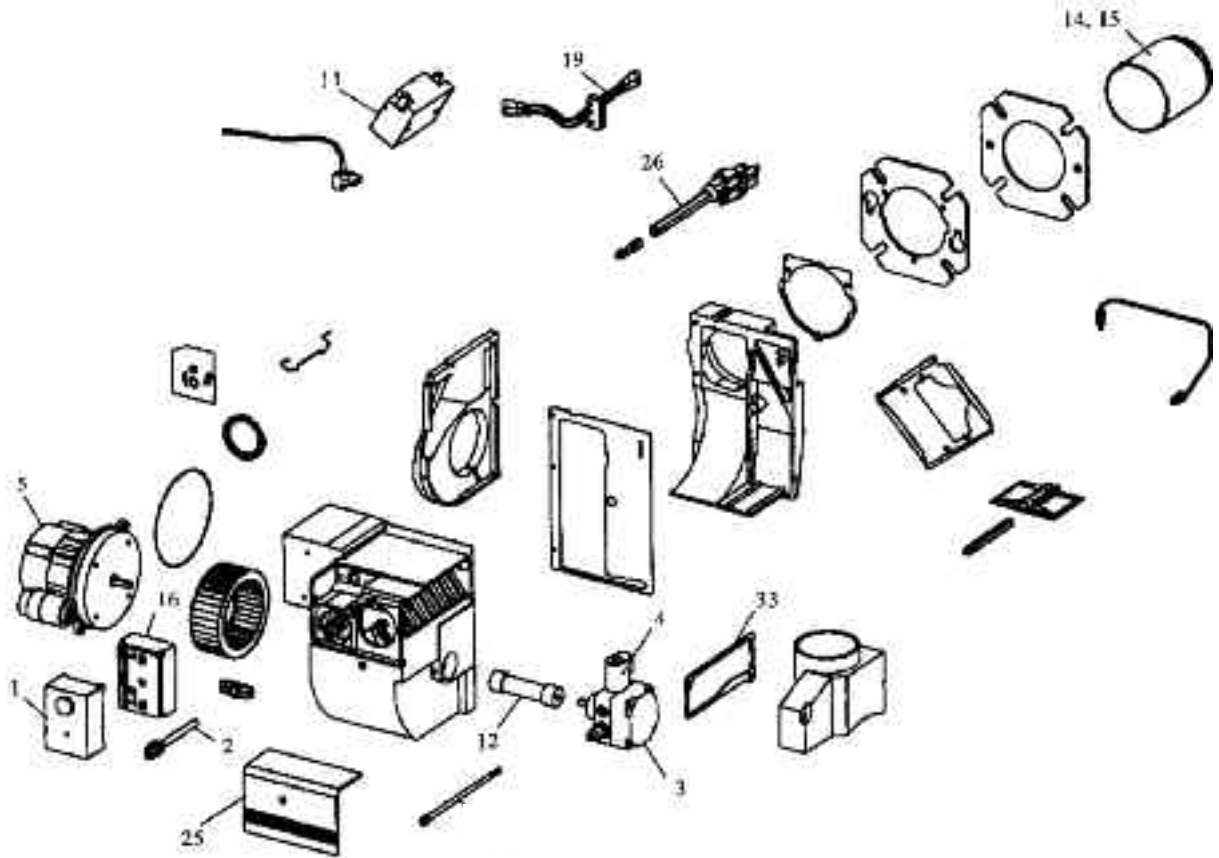

Key No.	Description	EOGB Part No.	Grant Part No.
1	Control box	SO1-TF830-2B	SBS01
2	Photocell	SO1-TMZ7705-80	SBS02
3	Pump	DO1-071N0142	SBS03
4	Solenoid coil	E01-071N-0010	SBS04
5	Motor	M02-1-125-02	SBS05
11	Transformer	D01-052F0030	SBS11
12	Drive coupling	B03-00-111-27823	SBS12
13	KA brake plate	B03-00-118-85801	SBS13
14	Burner head (140/160)	B03-00-117-28401	SBS14
15	Burner head (160/200)	B03-00-117-38514	SBS15
16	Control box base	S01-5071	SBS16
26	Nozzle/electrode assy.	B03-00-118-86701	SBS26
33	Air intake gasket	B03-00-119-05701	SBS33



When installing this appliance or ancillary parts, care should be taken to avoid injury from panel edges or objects likely to cause injury.

Under the Consumer Protection Act 1987 and Section 6 of the Health & Safety at Work Act 1974, we are required to provide information on substances hazardous to health (COSHH Regulations 1988).

Adhesives, sealants and paints used in the manufacture of the product are cured and present no known hazards when used in the manner for which they are intended.

The following other materials are present in the product:

Insulation materials

Material Types:	Ceramic fibre board, mineral wool.
Description:	Rigid board, slabs, sleeves, gaskets, ropes.
Known Hazards:	May cause temporary irritation or rash to skin. High dust levels may irritate eyes and upper respiratory system.
Precautions:	Avoid unnecessary or rough handling, or harsh abrasion of boards. Normal handling and use of material should not produce high dust levels. Avoid inhalation, and contact with skin and eyes. After handling always follow normal good hygiene practices.
Protection:	Use disposable gloves, face mask and eye protection.
First Aid:	Eyes – If irritation occurs, wash eyes with copious amounts of water. If symptoms persist, seek immediate medical advice. Skin – If irritation occurs, wash under running water before washing with soap and water. Inhalation – Remove to fresh air, drink water to clear throat and blow nose to remove dust/fibres. Ingestion – Drink plenty of water.

Sealants

Material Types:	Silicone elastomer.
Description:	Sealant and adhesive.
Known Hazards:	Irritation to eyes.
Precautions:	Avoid inhalation of vapour, contact with eyes and prolonged or repeated contact with skin. After handling always follow normal good hygiene practices.
Protection:	Use eye protection. Rubber or plastic gloves should be worn where repeated contact occurs and a face mask worn when working in confined spaces.
First Aid:	Eyes – Flush eyes with water for 15 minutes. Seek immediate medical attention. Skin – Wipe off and wash with soap and water. Inhalation – Remove to fresh air.

Kerosene and Gas oil fuels (Mineral oils)

Known Hazards:	The effect of mineral oils on the skin vary according to the duration of exposure and the type of oil The lighter fractions remove the protective grease naturally present on the skin, leaving it dry, liable to crack and more prone to damage by cuts, abrasions and irritant chemicals. Skin rashes (Oil acne) most often on arms, but also on any part of the body in contact with oil or oily clothing. Contact with fuel oils can cause dermatitis.
Precautions:	Avoid as far as possible any skin contact with mineral oil or with clothing contaminated with mineral oil. The use of lanolin-based barrier cream is recommended, in conjunction with regular washing with soap and rinsing with water to ensure all oil is removed from the skin. Take care to prevent clothing, especially underwear, from becoming contaminated with oil. Do not put oily rags or tools in pockets, especially trouser pockets. Have first-aid treatment at once for an injury, however slight. Do not inhale any vapours from mineral oils.





We declare that the Multi Pass range of Oil Boilers equipped with Riello RDB burner approved to EN 267: 1991 satisfy the requirements of the following European Directives:

1. 89/336/EEC - Electromagnetic Compatibility Directive
Referred to the generic standards EN 55014 : 1993 EN 50082 - 1 - 1992
2. 73/23/EEC - Electrical Equipment Safety Regulations Directive
Referred to the generic standard No: 3260: The Electrical Equipment (Safety) Regulations: 1994
3. 92/42/EEC - Hot Water Boiler Efficiency Directive
Referred to the generic standard - The Boiler (Efficiency) (Amendment) Regulations 1994
(SI 1994/3083)

Signed: _____

Managing Director
Grant Engineering (Ireland) Ltd.,
Crinkle, Birr, Co. Offaly, Ireland.

TERMS OF GUARANTEE

1. The company shall mean Grant Engineering (Ireland) Limited.
2. The Boiler is guaranteed for a period of 12 months from the date of installation providing that any work undertaken is authorised by the company and carried out by an approved service agent.
3. The shell (heat-exchanger) of oil boilers supplied by Grant Engineering (Ireland) Limited are guaranteed for a period of 5 years from the date of installation. All other boiler components, excluding consumables (such as nozzles and filters), for 1 year from the date of installation.
4. This guarantee does not cover breakdowns caused by incorrect installation, neglect, misuse, accident or failure to operate this boiler in accordance with the manufacturers instructions.
5. This guarantee is not transferable unless sanctioned by the Company.
6. The Company will endeavour to provide prompt service in the unlikely event of a problem occurring, but cannot be held responsible for any consequence of delay however caused.
7. This guarantee does not cover labour, handling or shipping.
8. This guarantee applies to boilers installed on the island of Ireland both north and south. Provision of the warranty cover elsewhere is subject to agreement with Grant Engineering (Ireland) Ltd.

Complies with the EC Low voltage,
Electromagnetic compatibility and
Boiler Efficiency Directives



89/336/EEC
73/23/EEC
92/42/EEC



GRANT
ENGINEERING LTD.

**GRANT ENGINEERING (IRELAND) LTD.,
CRINKLE, BIRR, CO. OFFALY.
Telephone: (057) 9120352/9120089**

This manual is accurate at the date of printing but will be superseded and should be disregarded if specifications and/or appearances are changed in the interests of continued product improvement.

All goods sold are subject to our official Conditions of Sale, a copy of which may be obtained on application.

© Grant Engineering Limited 2001. No part of this manual may be reproduced by any means without prior written consent.